

Emerging Trends in Engineering And Technology

Volume - 1

Chief Editor

Mohit Bajpai

Associate Professor, Electronics and Communication Engineering, Poornima
Institute of Engineering & Technology, Jaipur, Rajasthan, India

Co-Editor

Dr. A.V. Sudhakara Reddy

Associate Professor, R&D Coordinator, Department of Electrical and
Electronics Engineering, Malla Reddy Engineering College (Autonomous),
Maisammaguda, Secunderabad, Telangana, India

**Integrated Publications
New Delhi**

Published By: Integrated Publications

Integrated Publications

H. No. - 3 Pocket - H34, Sector - 3,
Rohini, Delhi-110085, India

Chief Editor: Mohit Bajpai

The author/publisher has attempted to trace and acknowledge the materials reproduced in this publication and apologize if permission and acknowledgements to publish in this form have not been given. If any material has not been acknowledged please write and let us know so that we may rectify it.

© **Integrated Publications**

Publication Year: 2021

Pages: 84

ISBN: 978-93-90471-48-5

Book DOI: <https://doi.org/10.22271/int.book.50>

Price: ₹ 694/-

Contents

S. No.	Chapters	Page No.
1.	ZSI Based-Motor Drive System for Electric Vehicles <i>(Dr. B. Karunamoorthy)</i>	01-15
2.	Data Acquisition System using Run Time Reconfigurable Technique Based on Embedded System <i>(B. Ravichandra Rao, Dr. P. Krishna Murthy, Dr. A. Pullareddy and Kesava Vamsi Krishna V)</i>	17-31
3.	Programming Logic Controllers (PLC's) <i>(Prof. Natash CP, Prof. Naveen CR and Prof. Santhosh Kumar TC)</i>	33-45
4.	An Overview of Machine Learning and Its Engineering Applications <i>(P. Kamalakar, S. Bharathi, G. Ravi Kishore and S. Santhipriya)</i>	47-59
5.	An Automatic Smart Energy Meter Reading System for Consumer Appliances <i>(Addanki Purna Ramesh, Narendrakumar Chinta, Suman Tenali and Sravanthi Kantamaneni)</i>	61-74
6.	A Novel Approach of Image De-Noising using Implementation of the DWT and HWT Techniques <i>(B. Malakonda Reddy, Raja Reddy Duvvuru, Dr. P. Hemachandu and Dr. A. Pulla Reddy)</i>	75-84

Chapter - 1
**ZSI Based-Motor Drive System for Electric
Vehicles**

Author

Dr. B. Karunamoorthy

Associate Professor, Department of Electrical and Electronics
Engineering, Kumaraguru College of Technology, Coimbatore,
India

Chapter - 1

ZSI Based-Motor Drive System for Electric Vehicles

Dr. B. Karunamoorthy

Abstract

In traction system the choice of motor is very important, multipurpose motors are available in the market. By considering the motor parameter like high power to weight ratio, high torque to current ratio with that high efficiency and robustness. Owing all the advantages the motor chosen is PMSM (Permanent magnet synchronous motor) for the variable speed modern drive which is most widely used in EV's (Electric vehicle and in Hybrid electric vehicle). Without weakening the field by controlling the DC-link voltage the PMSM machine can run at high speed by implementing ZSI to the drive system. Z source inverter working principle and modulation method is discussed in this study. By considering the Limitation of Maximum voltage and available line current a new Vector control scheme is developed for PMSM drive voltage boosting. At last the proposed system implementation effectiveness and reliability is tested by several simulation and experimental results.

Keywords: e-vehicle, ZSI inverter, ZSI based e-vehicle, DC-AC power conversion

1. Introduction

Increase in population is proportionally increased in internal combustion engine Automobile. This leads demand in natural resources and drastic increase in the price of petroleum products. By concerning the global problem all the IC engines should be replaced with Electric Motor which turns our attention to the research area Electric Vehicle (EV). The EV's are Eco friendly and no emission to the environment. In Idle speed it will not consume energy and also it will not produce any sound at the time of running.

A drive system is necessary for the Electric vehicle to control the speed from stand still to the maximum speed to propel the vehicle. Multiple motor and their drive system are available in market out of which Permanent magnet synchronous motor is very popular and attractive because of their reliability,

high power density and efficiency ^[5, 10]. To operate the motor in high-speed region, field weakening control scheme is utilized since the PMSM machine have a short constant-power region due to their limited field weakening capability ^[5], still it requires some more current to reduce the magnetic flux of the machine. In reference ^[6, 11], Dc-Link voltage is changed with boost converter connected in series with the PWM inverter for the rated speed of PMSM drive system. Z source inverter existing PWM technique total harmonic distortion is bigger due to unsymmetrical shoot through is discussed in ^[1]. Different modulation strategies impedance source network to generate DC to AC voltage is discussed in ^[2], MPC model predictive control discuss about the fast torque control of PMSM machine ^[4], Fuzzy logic-based vector control led PMSM machine speed control using DS1103 discussed in this paper ^[3].

A competitive alternative topology is introduced in single stage power converter and Z-source inverter due to the defects in tradition voltage inverter because of the complexity of the circuit and control, the two-stage system requires more space and proposed single stage ZSI is discussed in ^[7, 8, 12]. Both the buck and boost capabilities advantages adopted in the different applications are discussed in ^[7] and the same is discussed with Ac induction motor drive in ^[12]. A bidirectional Z source inverter with the steady state operating principle and voltage boosting modified vector control scheme of permanent magnet synchronous motor drive is presented in the paper.

Z source inverter both direction topologies has discussed in ^[20]. The discontinuous induction current causes unstable and un controllable ZSI, it can be overcome by operating the ZSI in Low load power factor or with small inductance ^[28], The system bidirectional power flow is discussed in ^[21]. The proposed circuit ZSI is used to feed current to PMSM machine as current fed Z-source DC/DC converter under the condition of reverse power flow. The complicated operation and increase in number of switches and their mode of operation are compared to ^[20]. Z source inverter, Pulse width modulation traditional inverter and DC/DC boosted PWM inverter are compared in ^[22, 29]. As per the comparison the ZSI Conversion efficiency of inverter and motor system efficiency is better when compared to the earlier two existing inverter system. In this survey PMSM drive system is controlled by Bi-directional Z source inverter as a single stage converter instead of a two stage converter (DC/DC converter bidirectional and VSI). In the next section, the working principle and pulse width modulation method and the equivalent circuit of the Bi-directional Z source inverter are discussed. Limitations of maximum line current and voltages of the Permanent magnet synchronous motor are

discussed in the next section. In the last section the experimental results and simulations results for the implemented drive system is shown.

2. Bidirectional z-source inverter

The proposed drive system is shown in the figure which consists of Permanent magnet synchronous motor connected with conventional voltage source inverter with a impedance network. The power to the circuit is fed by the Battery pack connected to it. The bidirectional power flow system ability is enabled by introducing switch S_7 . A PN junction diode is connected Anti parallel to S_7 which eliminates the discontinuous inductor current caused by undesirable mode of operation. To achieve the required properties two similar inductors and capacitors are connected in specific manner as shown in Fig. 1.

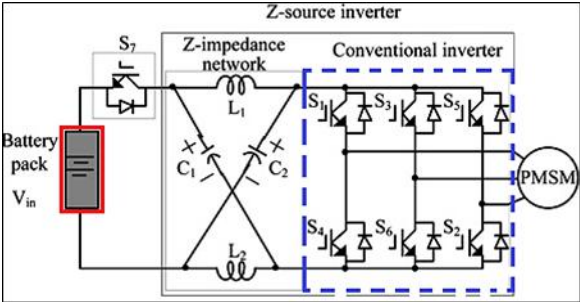

Fig 1: Bidirectional ZSI for PMSM drive

To maintain the output voltage the active states should be kept as same and partially replace the traditional zero states or the zero state to be shoot-through entirely based on voltage level required to boost base on our need. Each operating state characteristics are described separately as shown below.

From the equivalent circuit based on symmetry we have

$$V_{c1} = V_{c3} = V_{c2}, v_{l2} = v_{l1} = v_{l3} \dots (1)$$

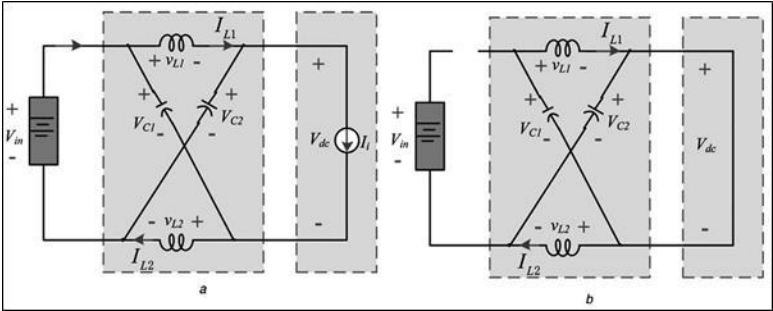

Fig 2: ZSI Equivalent circuits

2.1 Bidirectional ZSI PWM control strategy

Traditional voltage source converter uses various Pulse width modulation control methods at present. Traditional PWM methods will not use the shoot through state so to control the ZSI DC boost PWM methods need to be modified. The method we require is controllability in wide range AC output voltage and less harmonic. A technique that bridges PWM and Space vector control is space vector pulse width modulation (SVPWM) technique. Four PWM control methods are existing, Maximum constant boost control method is discussed in [23]. Simple boost control method is discussed in [15], Modified space vector control method discussed in [31] and maximum boost control method is discussed in [30]. In this paper for attaining variable speed application shoot through is control by using MSVPWM method.

While inverter is operated in shoot through state switch S7 has to be kept in OFF in the mode analysis of ZSI. Switch position remains in ON state when the inverter is operated in its non-shoot through states. Boost capacitor is used in non-shoot through state when inverter is operated in regenerating mode. In the different mode of operation whenever reverse current is monitored the switch S7 is closed permanently since because the battery receives constant reverse current.

3. Pmsm drive system design

3.1 Current and voltage range

The rotor reference frame steady state voltage equation of PMSM is,

$$T_e = P \frac{3[i_{sq}\lambda_{pm} + i_{sq}(L_d - L_q)i_{sd}]}{2} \quad \dots (2)$$

$$\begin{bmatrix} V_{sd} \\ V_{sq} \end{bmatrix} = \begin{bmatrix} L_d P + R & -L_q \omega_e \\ L_d \omega_e & L_q P + R \end{bmatrix} \begin{bmatrix} i_{sd} \\ i_{sq} \end{bmatrix} + \begin{bmatrix} 0 \\ \lambda_{pm} \omega_e \end{bmatrix} \quad \dots (3)$$

Where, d- and q-axis current sare the i_{sd} and i_{sq} currents; d-and q-axis voltages are v_{sd} and v_{sq} voltages; d-and q-axis inductances are the L_d and L_q ; Stator resistance is the R ; Electrical angular frequency is ω_e ; number of pole pairs is P and electromagnetic torque T_e d/dt is the derivative operator of p ; flux linkage is λ_{pm} respectively.

$v_{s \max}$ maximum available voltage and $i_{s \max}$ maximum line current amplitude of the motor with that we can get the following equation.

$$v_{sq}^2 + v_{sd}^2 \leq v_{s \max}^2 \quad \dots (4)$$

$$i_{sq}^2 + i_{sd}^2 \leq i_{s \max}^2 \quad \dots (5)$$

In high-speed operation by neglecting the armature resistance drop, in steady state the derivative operator P becomes zero by substituting (4) and (5) into (2), With that we can obtain an voltage constraint equivalent as follow,

$$(i_{sq}L_q)^2 + (\lambda_{pm} + L_d i_{sd})^2 \leq \frac{v_s^2 \max}{\omega_e} \quad \dots (6)$$

3.2 Maximum torque per ampere operation (MTPA)

Motor parameters depends on the MTPA trajectories, MTPA operation can be done and IPM motor has a saliency (L_q, L_d) With the reluctance torque.

The following equation obtains the operating point as follows, the operating point can be obtained by the following equations simplified is,

$$i_{sq} \leq \sqrt{i_s^2 \max - i_{sd}^2} \quad \dots (7)$$

$$i_{sd} = -i_{sq}^2 \frac{(L_q - L_d)}{\lambda_{pm}} \quad \dots (8)$$

3.3 Current range of the battery

To run a motor above its rated speed with constant power and also to operate below rated speed with the same power when current of the battery is limited. When motor draws the rated current that value corresponds to the DC-link Current. I_{BTmax}

Current value is limited by considering the parameters and characteristics of the battery. The below equation defines the maximum torque output of the machine.

$$T_{\max} = \frac{I_{BT \max} V_{in}}{\eta \omega_r} \quad \dots (9)$$

Constant torque can be achieved only if the current of the battery is not limited; if the current of the battery is limited then I_{DC} DC-Link current is as follows.

$$I_{DC} = I_{BTmax} \eta \left(\frac{V_{in}}{V_{DC}} \right) \quad \dots (10)$$

Therefore the VDC DC-link voltage increases as the I_{DC} decreases. In other words, current I_{BTmax} , for the constant battery the current limited circle shrinks as the speed increases.

4. Control design

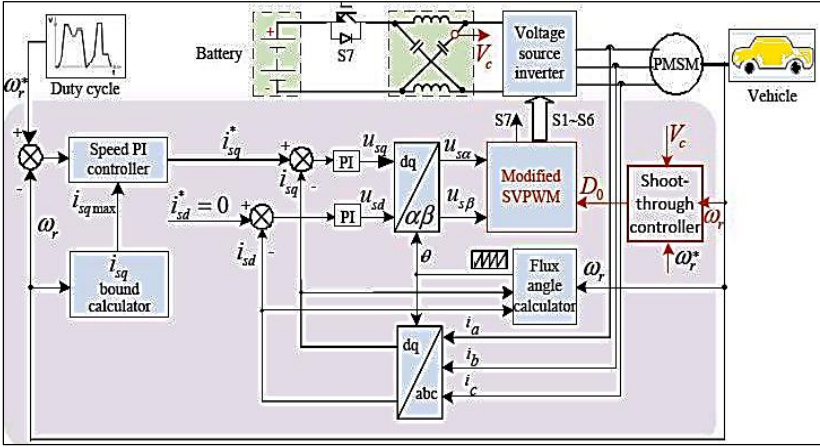

Fig 3: Control scheme PMSM with Bi-directional ZSI

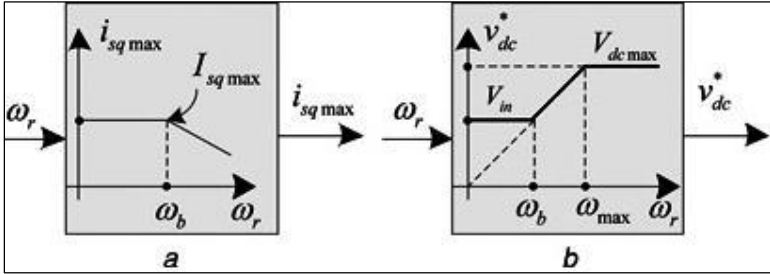

Fig 4: Functional diagrams a) i_{sq} current calculator b) voltage command generator DC-link

Fig. 3 show the functional diagram of i_{sq} bound calculator. The q-axis current is the output maximum amplitude and rotor speed is the input parameter. Maximum line current of the motor is limited using speed PI controller in the zero d-axis control modes such that current of the battery will not exceed the limit. Fig. 4(b). Shows the command block of the DC-link, ω_r rotor speed is less than the rated speed ω_b , Z source inverter will operate without the DC-link voltage command and boost which are equal to the applied input voltage. In the high speed operation the rated input voltage should apply higher. Feedback signal cannot be selected because of the DC-link voltage in the shoot through state of Z source inverter. The duty ratio D_0 shoot through time by controlling it V_c capacitor voltage of the Z-source can be increased. So in this paper, v_c is selected as feedback signal to control v_{dc} indirectly. In order to overcome the nonlinear problem between v_{dc} and v_c , a linear capacitor voltage controller^[9] is adopted. The task of shoot through controller in Fig.3 is to generate D_0 .

5. Simulation results

Saber software is used to take the simulation result. Bidirectional ZSI based proposed PMSM drive system for an electric vehicle by considering the PMSM parameters like, battery, Z-source network, Transmission system are listed in the Table 1.

Table 1: System Parameters

Component	Parameter	Value
Transmission system	Ratio	1:2
	Efficiency	0.91
PMSM	Rated speed	51 rad/s
	Rated torque	339 Nm
	d-axis inductance (L_d)	9 mH
	q-axis inductance (L_q)	8.5 mH
	Flux of field	0.7 Wb
	Rated output power	17 kW
	Armature resistance (R)	0.4375 ohm
	Pole number	8
Battery	Rated capacity	100 A h
	Rated voltage (EBT)	410 V
Vehicle	Aerodynamic drag coefficient	0.3
	Gross mass	990 kg
	Rolling resistance coefficient	0.015
	Radius of wheels	0.288
	Frontal area	1.7 m ²
Z-source network	Capacitor	300 μ F
	Inductor	36.5 μ H

The electric vehicle proposed drive system dynamics and effectiveness are simulated extensively through saber. The table 1 list all the parameters. The different operating mode of the system is detail shown in Fig. 5. ZSI driven PMSM characteristics and simulation results are shown in Fig.7. The rated torque is achieved in the time interval of 0.4-3.9 s in the acceleration mode. 3.9-4.2s time interval requires to reach the rated speed in cruise mode. 4.2-11s requires to decrease in torque in acceleration mode. 11-12s, time interval to reach the maximum speed in cruise control mode. 12-18s required to reach maximum speed to rated speed in regenerative braking mode. 20-23.5s time intervals required for regenerative braking mode with the rated torque. 18-20s time intervals with the rated speed requires in cruise operation mode. Here, a dip is observed in the battery current and the q-axis current

waveforms at 3.9 s. This is because the vehicle's resistance decreasing significantly during the time interval (3.9-4.2 s), where the vehicle is in cruise operation mode. The shoot-through time duty ratio, boost factor, DC-link voltage and capacitor voltage of PMSM driven by ZSI against speed characteristics presented in Fig. 7.

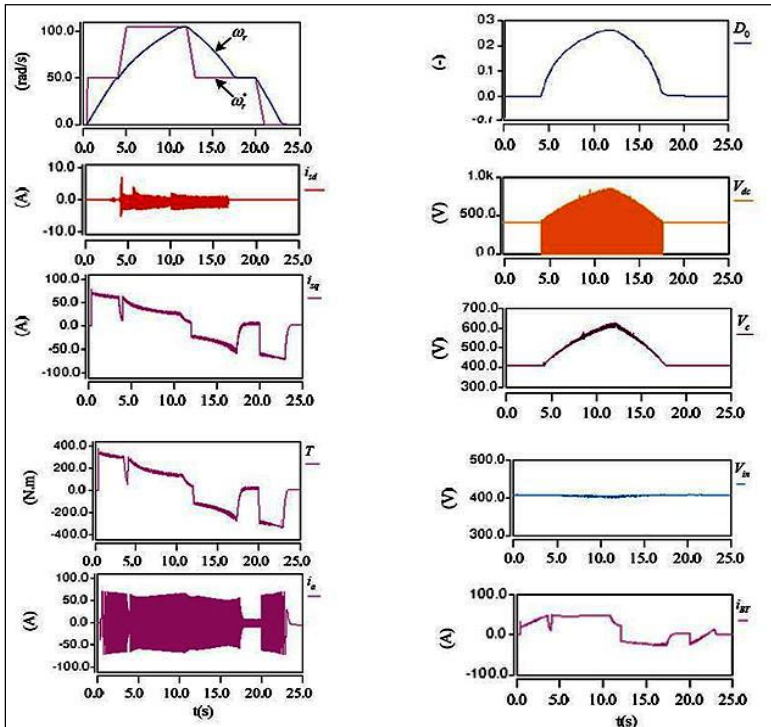

Fig 5: PMSM driven by ZSI Transient waveforms

Fig. 6. ZSI operation Characteristic.

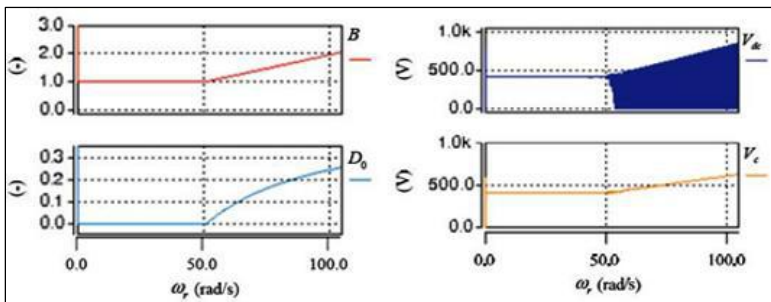

Fig 7: (a) speed characteristics vs shoot-through and Boost factor time duty ratio (b) speed characteristics vs capacitor voltage versus and DC-link voltage

Fig. 5-7, one finds the following mentioned below,

- Above the rated speed the d- axis current kept zero. Hence there is no additional current required to reduce the flux of the motor.
- Since i_{BT} is negative bidirectional power flow is possible in regenerative braking mode.
- Input voltage and DC-link voltage are equal at rated speed while ZSI working in non-shoot through mode.

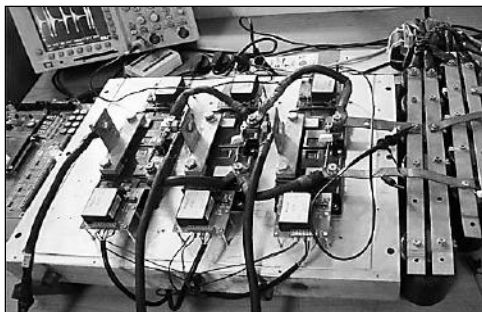

Fig 8: ZSI experimental set-up

Using the table 1 parameters the bidirectional Z source inverter prototype for PMSM drive is designed and implemented in the laboratory set up. For the switching frequency generation the TMS320F2808 board has chosen to generate 10KHZ system frequency for testing the proposed control methods and realization. Code generation is done with code composer studio for the real time control. DAC 12-bit resolution is used to find the wave forms and inspect in oscilloscope. System functional block is shown in the Fig. 7. Laboratory setup is shown in Fig. 8. Bidirectional ZSI switches (S1-S7) and intelligent power module PM800HSA120 is used. Fig. 9 shows the d-axis current, stator current, speed command and motor speed, DC-link voltage and battery voltage; motor speed and capacitor voltage short-through time duty ratio; respectively, which are quite consistent with the simulation results.

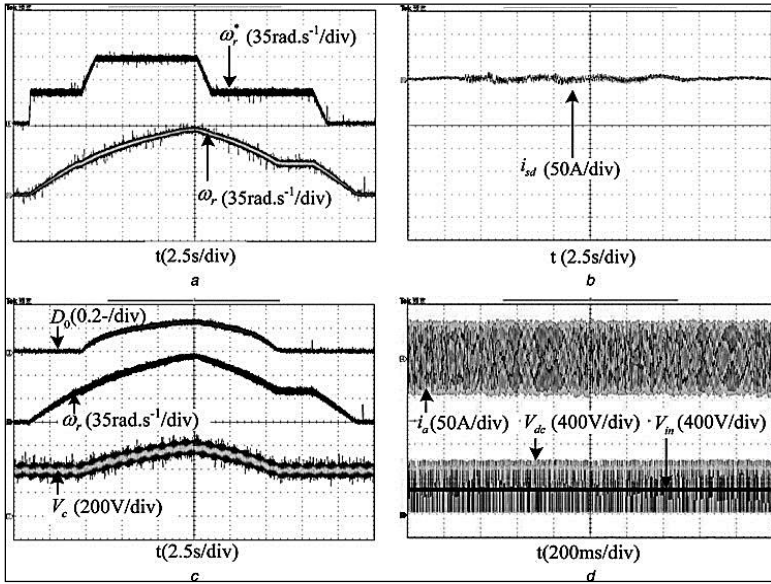

Fig 9: Experimental result of characteristics for PMSM driven by ZSI (a) motor speed and Speed command (b) current d-axis (c) capacitor voltage, motor speed and Short-through time duty ratio (d) battery voltage, Stator current, DC-link voltage

6. Conclusion

The bidirectional Z source inverter is presented in the paper. The main focus is to increase the speed range of permanent magnet synchronous motor by reducing the amplitude of the current in the high-speed region, this is achieved by gating simultaneously both the lower and upper switches of the same phase leg, when the speed of the machine goes higher than the rated speed. The shoot through of the circuit no longer disturbs the system and hence the reliability goes higher. It is a stable low-cost single stage highly efficient system. The experimental result is compared with the simulated result and the simulated results were validated. In the proposed system the D-axis current is totally eliminated in the constant power region, obviously in the flux weakening operation the copper loss of the motor will be reduced.

References

1. Sumant G Kadwane, Umesh K Shinde, Snehal P Gawande, Ritesh Kumar Keshri. Symmetrical Shoot-Through Based Decoupled Control of Z-Source Inverter IEEE Access Year. 2017; 5:11298-11306.
2. Yam P Siwakoti, Fang Zheng Peng, Frede Blaabjerg, Poh Chiang Loh, Graham E Town, Shuitao Yang. Impedance-Source Networks for Electric

3. Siti Noormiza Mat Isa, Zulkifilie Ibrahim, Jurifa Mat Lazi, Md Hairul Nizam Talib, Nurazlin Mohd Yaakop, Ahmad Shukri Abu Hasim. "dSPACE DSP based implementation of simplified fuzzy logic speed controller for vector controlled PMSM drives" 2012 IEEE International Conference on Power and Energy (PECon) Year, 2012, 898-903.
4. Shinji Doki, Shigeru Okuma. Fast torque control system of PMSM based on model predictive control Yuya Hozumi; 35th Annual Conference of IEEE Industrial Electronics Year, 2009, 1151-1155.
5. Zhu ZQ, Howe D. Electrical machines and drives for electric, hybrid, and fuel cell vehicles, Proc. IEEE. 2007; 95(4):746-765.
6. Zhu ZQ, Chan CC. Electrical machine topologies and technologies for electric, hybrid, and fuel cell vehicles'. Proc. IEEE Vehicle Power and Propulsion. Conf., 2008, 1-6.
7. EL-Refaie AM, Jahns TM. Comparison of synchronous PM machine types for wide constant-power speed operation: converter performance, IET Electr. Power Appl. 2007; 1(2):217-222.
8. Krishnan R. Permanent magnet synchronous and brushless DC motor drives (CRC Press, 1st edn.), 2009.
9. Yamamoto K, Shinohara K, Imakiire A. Steady-state characteristics of PWM inverter with voltage boosters for permanent magnet synchronous motor drives. Proc. IEEE Power Conversion. Conf. 2007, 296-301.
10. Chan CC. The state of the art of electric, hybrid, and fuel cell vehicles, Proc. IEEE. 2007; 95(4):704-718.
11. Chau KT, Chan CC, Liu CH. Overview of permanent-magnet brushless drives for electric and hybrid electric vehicles, IEEE Trans. Ind. Electron. 2008; 55(6):2246-2257.
12. Pellegrino G, Vagati A, Guglielmi P, Boazzo B. Performance comparison between surface mounted and interior PM motor drives for electric vehicle application', IEEE Trans. Ind. Electron. 2012; 59(2):803-811.
13. Yamamoto K, Shinohara K, Nagahama T. Characteristics of permanent-magnet synchronous motor driven by PWM inverter with voltage booster, IEEE Trans. Ind. Appl. 2004; 40(4):1145-1152.

14. Yamamoto K, Shinohara K, Furukaw S. Permanent magnet synchronous motor driven by PWM inverter with voltage booster with regenerating capability augmented by double-layer capacitor, IEE J Trans. IA. 2006; 126(5):639-645.
15. Peng FZ. Z-source inverter, IEEE Trans. Ind. Appl. 2003; 39(2):504-510.
16. Yamamoto K, Shinohara K, Makishima H. Comparison between flux weakening and PWM inverter with voltage booster for permanent magnet synchronous motor drive. Conf. Rec. PCC-Osaka, 2002, 161-166.
17. Huang Y, Shen M, Peng FZ, Wang J. Z-source inverter for residential photovoltaic systems, IEEE Trans. Power Electron. 2006; 21(6):1776-1782.
18. Peng FZ, Joseph A, Wang J *et al.* Z-source inverter for motor drives, IEEE Trans. Power Electron. 2005; 20(4):857-863.
19. Peng FZ, Shen M, Holland K. Application of Z-source inverter for traction drive of fuel cell-battery hybrid electric vehicles, IEEE Trans. Power Electron. 2007; 22(3):1054-1061.
20. Xu H, Peng FZ, Chen L, Wen X. Analysis and design of bi-directional Z-source inverter for electrical vehicles. Proc. IEEE Applied Power Electronics. Conf., 2008, 1252-1257.
21. Yamanaka M, Koizum H. A bi-directional Z-source inverter for electric vehicles. Proc. IEEE Power Electronics and Drive Systems. Conf., 2009, 574-578.
22. Shen M, Joseph A, Wang J, Peng FZ, Adams DJ. Comparison of traditional inverters and Z-source inverter for fuel cell vehicles, IEEE Trans. Power Electron. 2007; 22(4):1453-1463.
23. Shen M, Wang J, Joseph A, Peng FZ, Tolbert LM, Adams DJ. Maximum constant boost control of the Z-source inverter. Proc. IEEE Industry Applications Conf., 2004, 142-147.
24. Novotny DW, Lipo TA. Vector control and dynamics of AC drives (Oxford University Press, New York), 1997.
25. Vinh T, Chun T, Ahn J, Lee H. Algorithms for controlling both the DC boost and AC output voltage of Z-source inverter, IEEE Trans. Ind. Electron. 2007; 54(5):2745-2750.
26. Dehghan SM, Mohamadian M, Varjani A. A new variable-speed wind energy conversion system using permanent-magnet synchronous

- generator and Z-source inverter, *IEEE Trans. Energy Converters*. 2009; 24(3):714-724.
27. Rajaei AH, Mohamadian M, Dehghan SM, Yazdian. Single phase induction motor drive system using z-source inverter, *IETElectr. Power Appl.* 2010; 4(1):17-25.
 28. Karunamoorthy B, Somasundareswari D. Effect of Stability Analysis Using Electromagnetic Interference in Grid-Connected Z-source Inverters, *JSIR*. 2015; 74(4):212-216.
 29. Shen M, Joseph A, Wang J, Peng FZ, Adams DJ. Comparison of traditional inverters and Z-source inverter. *Proc. IEEE Power Electronics Specialists Conf.*, 2005, 1692-1698.
 30. Shen M, Peng FZ, Qian Z. Maximum boost control of the Z-source inverter, *IEEE Trans. Power Electron.* 2005; 20(4):833-838.
 31. Liu J, Huang J, Xu L. A modified space vector PWM for z-source inverter-modeling and design. *Proc. IEEE Electrical Machines and Systems. Conf.*, 2005, 1242-1247.
 32. Uddin MN, Chy MMI. A novel fuzzy-logic-controller-based torque and flux controls of IPM synchronous motor', *IEEE Trans. Ind. Appl.*, 2010, 46, 1220-1229.

Chapter - 2

Data Acquisition System using Run Time Reconfigurable Technique Based on Embedded System

Authors

B. Ravichandra Rao

Assistant Professor, Department of EEE, G Narayanamma Institute of Technology and Science, Hyderabad, Telangana, India

Dr. P. Krishna Murthy

Associate Professor & Head, Department of ECE, Chadalawada Ramanamma Engineering College, Tirupati, Andhra Pradesh, India

Dr. A. Pullareddy

Associate Professor, Department of ECE, Chadalawada Ramanamma Engineering College, Tirupathi, Andhra Pradesh, India

Kesava Vamsi Krishna V

Associate Professor, Dept. of Physics, Malla Reddy Engineering College (Autonomous), Hyderabad, Andhra Pradesh, India

Chapter - 2

Data Acquisition System using Run Time Reconfigurable Technique Based on Embedded System

B. Ravichandra Rao, Dr. P. Krishna Murthy, Dr. A. Pullareddy and
Kesava Vamsi Krishna V

Abstract

Normally, Data acquisition (DAQ) is used to acquire the signals from different devices like sensors, transducers, actuators etc. The data acquisition is also used to analyze the signals, digitizing the signals and acquiring the signals from different inputs. The DAQ is used in many applications like medical, agriculture, industries etc. In medical applications, it is used to monitor the ECG, pressure level for the particular patient. In the industrial application, it is used to acquire and monitor the different biomedical sensors or signals. The main drawbacks in data acquisition system are data storage, hardware size and remote monitoring. To enable monitoring of the most important physical and chemical culture parameters of hematopoietic stem cells in real time, including physicochemical parameters, nutrients and metabolites the above proposed hardware can be realized up to eight data acquisition modules that can be combined and connected to the host PC. Further these reconfigurable embedded systems can be extended to wireless DAQ.

1. Introduction

A VLSI based embedded system plays a key role in the modern technologies. The exploration based on wireless network is difficult with less power consumption due to the nodes in the environment. A run time hardware/software reconfigurable computing technique for wireless sensor network is proposed in this work. This technique reduces the hardware complexity, designer time and size when compared with the previous modules. The real time embedded applications are widely used as they play major role in reducing the production cost and create in industries real world safety environment. The run time reconfigurable technique plays a major role in wireless sensor networks for efficient data transmissions. In recent days, most of the industrial applications work to minimize the size and cost

of the device. The foremost improvement of the reconfigurable technique is that it circumvents the unnecessary hang and deferral in the device performance.

The major part of the industrial wireless sensor is an ultra-low power wireless sensor node which collects the processing signals from the particular location and transmits the information to a base station through wireless networks for controlling and monitoring. If the interfaces and data processing is done between the sensors, then the communication is very difficult from one sensor to another and it also varies from one application to another application. So the designers are trying to overcome these problems in their day to day environment by programming and reprogramming with application-specific hardware designs. In olden days, FPGAs were limited to performing the tasks that required only the fixed-point arithmetic, but in the recent advances, hardware's have made floating-point arithmetic on FPGA.

Reconfigurable computing involves the use of reconfigurable devices such as FPGAs for computing purposes. Reconfigurable computing is also known as configurable computing or custom computing. The advantages of reconfigurable computing includes reduction in size and component count (and hence cost), improved market demand, improved flexibility and upgradability. These advantages are specifically important for embedded applications. The FPGAs are used to accelerate computationally intensive scientific computing applications that require floating-point arithmetic operations that has to be done in a efficient manner.

2. Sensor node system

The distinguishing characteristic in hardware is that it has been designed in order to provide flexibility and adaptability, by applying modularity at the physical hardware level through a layered Printed Circuit Board (PCB) structure and providing it with reconfigurable hardware FPGA. Modularity allows dividing and encapsulating the functionality included in the node. Therefore, future redesigns may involve only part of the platform, which is desirable considering market demand, evolving technologies and standards. Moreover, due to the node flexibility, it is possible to carry out a design space exploration for the hardware node, by interchanging different implementations for each layer, depending on the application. In this section, an over-all part of the processing layer unit and the WSNs node parts are discussed. Both the engineering based and speculative related approaches are proposed. ARM and FPGA act as the processing layer unit. The hardware is composed of four main layers: ARM processing, power supply,

communications layer and sensors layer with each layer carrying out a specific task.

3. Arm LX2378

In the ARM, the ADC is one of the special units when compare to the previous microcontroller families which avoids the unwanted power consumption. ADC plays a major role in this work and it is the input part of the controller unit. The LPC2377/78 microcontrollers are based on a16-bit/32-bit ARM7TDMI-S (Manoj Gupta *et al.* 2009) CPU with real-time emulation that combines the microcontroller with 512 KB of embedded high-speed flash memory. A 128-bit wide memory interface and unique accelerator architecture enable 32-bit code execution at the maximum clock rate. For critical performance in interrupt service routines and DSP algorithms, this increases performance up to 30% over Thumb mode. For critical code size applications, the alternative 16-bit Thumb mode reduces code by more than30% with minimal performance penalty.

Various 32-bit timers, an improved 10-bit ADC, 10-bit DAC, PWM unit, a CAN control unit, and up to 104 fast GPIO lines with up to 50 edge and up to four level sensitive external interrupt pins make these micro-controllers suitable for industrial control. In the analog operation, the designer required ADC to attain low power consumption, reduced delay in the design process and to have inbuilt interface under the ARM based design.

4. Power supply and communication layer unit

Power supply generates all voltages needed within the hardware. The communication layer unit deals with a Zigbee module and Ethernet module for the data transmitting and receiving. It is controlled by ARM through the serial communication of Universal Asynchronous Receiver Transmitter (UART), which allows power supply from a PC, as well as serial programming for the microcontroller. Future it can be tried with WiFi, Universal Serial Bus (USB) and Bluetooth if the node distances are to be increased.

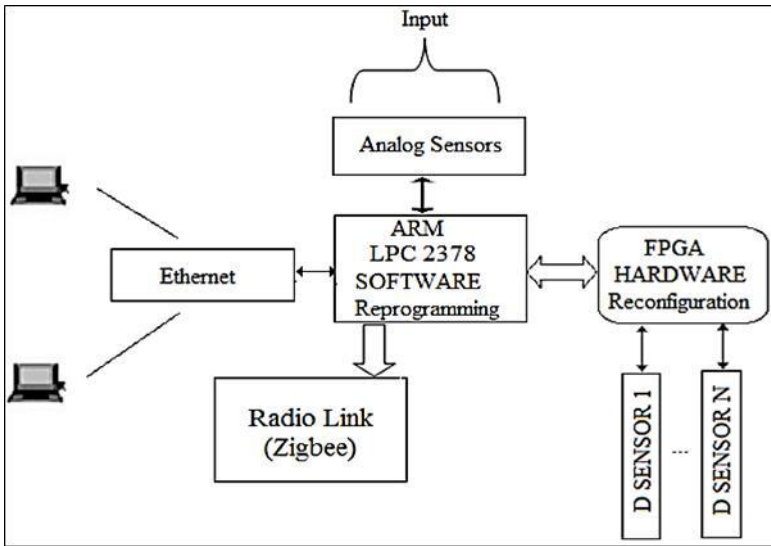

Fig 1: The architecture of a sensor node system

Sensor Layer Unit The major part of the industrial wireless sensor is an ultra-low power wireless sensor nodes which is shown in Figure 1. The sensor layer has one of the additional features that are the interfacing between both analog and digital sensors. The analog sensor (Temperature) is connected with ARM microcontroller and the digital sensors are connected with FPGAs. Here the digital sensors are considered in a generalized manner which depends on the output from the microcontroller. The FPGA controls the digital sensors and the information is passed through the serial cable when there is a change in the environment. The controller automatically passes the trigger to the FPGA. It checks the current status of the digital sensors and again it replies back the strategy to the microcontroller. This event is being as termed Runtime Reconfiguration. During this process any changes in both hardware and software does not affect the whole process, it only make changes the particular partial reconfiguration that depends on the coding and real time environment. This changes the remaining process to run in a parallel manner. This is the main speciality of the FPGA due to the interconnection between the blocks and wires so that it saves most of the power loss and at the same time it reduces the designer work time. In recent days, there are lot of myriad sensors that are available in the market with many different interfaces. Most of them are digital sensors with various categories such as I2C, SPI, 1-Wire, etc. First the signals are processed by the microcontroller when the problems arise due to timing. Some manufacturers provide Hardware Description Language (HDL) code to

implement the sensor interfaces in a coprocessor. A digital sensor is an electrochemical sensor, where data transmission and data conversions are done in a digital manner. Sensors are commonly used for analytical measurements, i.e., the measurement of physical and chemical properties of liquids. Some of the measured parameters are pH value, oxygen, conductivity, redox potentials etc.

5. Reconfiguration scenarios of node and control flow

Network level-based reconfiguration is the first reconfiguration scenario. This is one of the most required processes during deployment and the response of final function of each node is defined. This layer includes the sensors and data processing of the network that may get any affected or changed in any emergency situation. Substantially this scenario may put-on both the hardware reconfiguration technique and software reprogramming. In the context of node platform, hardware reconfiguration is compulsory when modifications affect digital sensors, as they are directly fastened with the FPGA. But the software reprogramming is required for analog sensors due to fastened process in the ARM ADCs. Reconfiguration at Node Level is the second scenario, which mainly involves the hardware configuration.

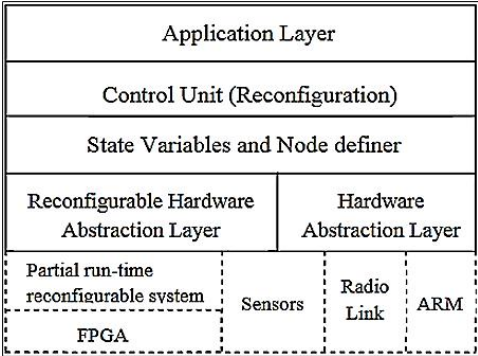

Fig 2: Software stacks of reconfigurable node

In this scenario, a reconfigurable array blocks act as a reconfigurable coprocessor to reduce the repetition task by the node platform hardware device FPGA and transmit data in a parallel manner. This parallel task is done with the help of reconfigurable array blocks. Here the FPGA has two main functionalities one deals with the analog sensor where it fully act as a coprocessor and another functionality deals with the digital sensors where it is acting as both coprocessor and digital sensor control. According to these scenarios, a partial runtime reconfiguration technique has been built on the top of the node. The run time reconfiguration allows modifying the data

processing, digital sensor interface or the interface between ARM and FPGA and also processing them when the system is in runtime. The ARM is the core element for controlling all the reconfigurable process which of receives the software reprogramming and hardware configuration that change and manage with the FPGA reconfiguration. Therefore, all the reconfigurable process is controlled by the simple software coding parts done by the designer.

The bottom of the node as shown in Figure 2 is the abstraction layer part which has various platforms that consists of both hardware and software library files. The one unit of the abstraction layer is traditional hardware abstraction layer and the remaining one is reconfigurable hardware abstraction layer. The software programmer makes the FPGA blocks to depend on the functionality. Below the abstraction layer, is the node definer and state variable unit part that indicates the future work of the node. It has some compressed messages like radio communication, sensor working unit, sensors working part and the variables that define the current status of the resource node. Another layer is controlling unit part which controls the node decision part. In this the node should take their decision in an independent manner when the reconfiguration is needed for data transfer from one node to another. If the reconfiguration is not available then the node decides independently in the decision part and transfers data. The final top most layers are application layer which decides the transmitting, receiving, sensing, data processing, etc.

6. Role of partial runtime system in WSN

The partial runtime system is the most efficient technique for runtime reconfiguration and most of the parallel processing industrial applications are based on these techniques. The file based on partial configuration is in a compact manner. During the runtime or in normal working condition, it attains only less amount of energy and bandwidth. The designer needs to make the partial reconfiguration to allocate the Configurable Logic Blocks (CLB) for the specific operations in a correct manner. The Proposed work tries to improve the efficiency of data transmission in runtime reconfigurable techniques for wireless sensor network. The most efficient thing is whenever the task is allocated in dynamic manner; the changes are automatically incorporated both in the hardware and software configuration on runtime condition. In the Proposed system, the FPGA reconfigurable blocks are arranged based on Virtual Architectures (Vas). The virtual architecture is divided into three major functionalities, the first one is between microcontroller and FPGA which does interfacing operations, the second one

is a digital sensor accessing part which deals the sensors in a generalized manner and the final one is in between these two major functionality which is the columns. Each Configure Logic Block (CLB) is a combination of four Lookup Tables.

The Spartan 3 FPGA has 16 CLB columns and 24 CLB rows and each have some special slot functions. In this proposed work, the reconfigurable FPGA has three major functions. The first one is sensor interfacing part, the second one is reconfigurable part (Co processing unit) and the final one is FPGA and ARM interfacing part as shown in figure 3.

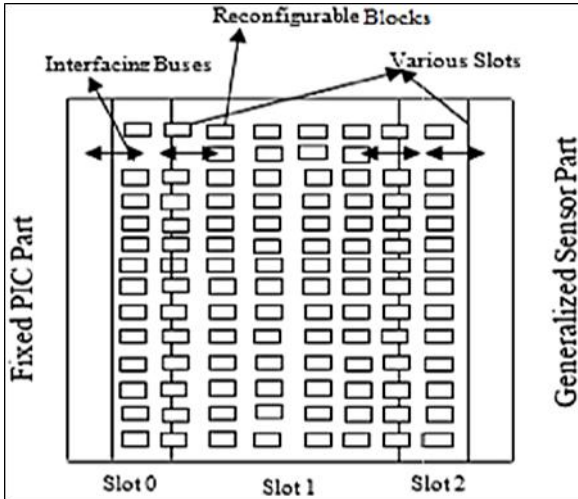

Fig 3: FPGA Virtual Architecture View and Slot Allotments for Node and Hardware

Thus, all functions are to be split as three slots, the first slot 0 for ARM communication with the FPGA, then slot 1 for reconfigurable function and slot 2 for sensor interfacing. All these interfacing works are done with the help of Buses. In this both unidirectional and bidirectional buses are used for data transferring between the slots. By the use of bidirectional bus, the data is moved from left to right (4 bits) at the same time the data transfer is done from right to left (4 bits) and also pipelining techniques are used in this architecture concept. This reduces most of the delay in the data transmission which may change due to environmental condition, cables and working mode. Further also reduces the data transmission speed and the delay timings are as explained below.

7. Processing layer

The result and parameter analysis part, mainly concentrates on memory usage and energy consumption. These two things relate to the term of cost.

In the proposed work parameters analyze in I) the reconfigurable systems which is used in wireless sensor network and II) reconfiguration on new hardware configurations and software programs for wireless sensor network is done.

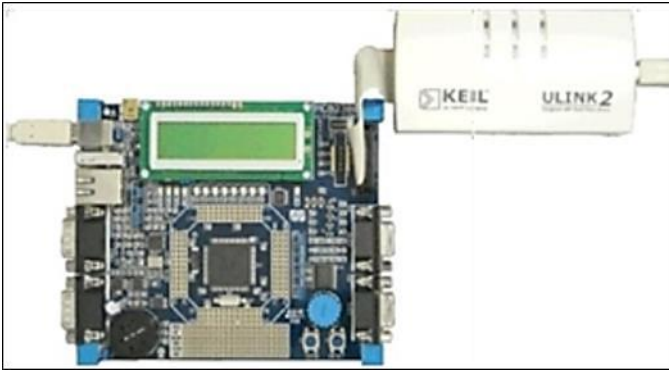

Fig 4: MCB2300 board processing layer units

The hardware part design is done with the help of MCB2300 board (Figure 4) The inbuilt process layer is used to control the active and passive components. The ARM act as a heart of the nodes for all the controlling functions and reconfigurable function which would be carried out by the microcontroller and the send a data at the same time. The environment conditions that depend on the reconfigurable function are analyzed to design in wireless sensor networks and the node can be increased depending on the application. The simulation result clearly show that the exact reconfigurable process of the FPGAs depend upon the receiving inputs from the ARM to FPGAs. The FPGA ensured the transmitting part from FPGA to ARM depends on the environmental condition and then the reconfiguration Processors. The process is done in the FPGA side to check the digital sensors conditions continuously. Any change in the interior side of the valve is intimated to the processor through the bidirectional bus. This result shows the simulation output of a reconfigurable process between the controller and FPGA kit.

8. Hardware implementation

The below Figure 5 shows the hardware implementation of the project which act as a processing layer unit. The FPGA is the processing layer unit which is done for the reconfigurable process in the kit LPC2378 to be placed in the center. The output is seen through separate protocol with the help of Ethernet which is used for viewing the results and the exact temperature conditions of the interior valve.

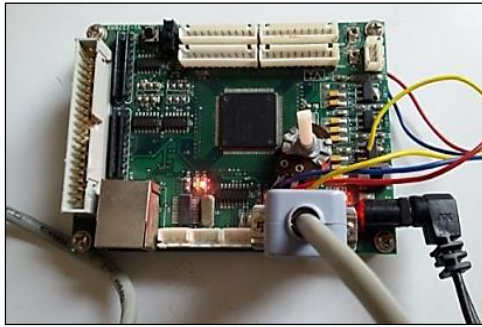

Fig 5: Hardware implementation of ARM LPC2378

9. Flash magic device software

Flash magic software Figure 6 is used to dump the program in ARM kit.

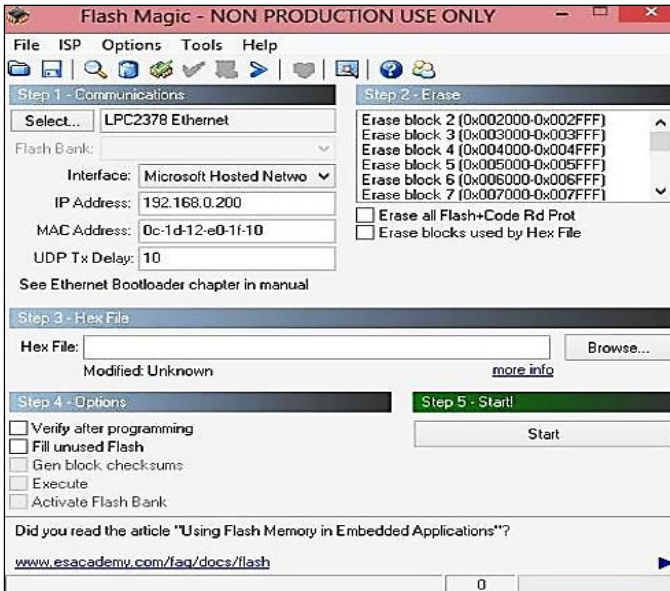

Fig 6: Flash Magic Device Software

Here the step1 process is to choose the device LPC2378 and the COM port depending on the PC. Then fix the baud rate as 38400 and analyze with different baud rate which is the speed one for dump process and set the clock frequency as 12MHz. In the step2 process, mark the erase blocks used by Hex file and in step3 browse the hex file in the PC location. The step4 is used to verify after programming and finally click start in step5.

10. Result analysis and conclusion

This work tries to improve the efficiency of data transmission in runtime reconfigurable techniques in wireless sensor network. The results validate high speed and secured data acquisition system using ARM based embedded Ethernet system design. The results prove reduction in the circuit size, cost and power consumption by the proposed DAQ as shown in Figures 7-10. This developed system achieves high resolution with memory reduction, reduced hardware size, fast remote monitoring and control. Table 1 shows the comparison of proposed data acquisition system with classical method. To achieve runtime re-configurability in there configurable computing area, the proposed system is further modified and developed with FPGAs and ARM processors.

Table 1: Comparison of proposed data acquisition system

Data Acquisition System	Data rate speed (GB/s)	Storage Capacity	Hardware Size (mm ²)	Power Consumption (mW)
Classical	8.80	32%(32X16384)	25.56	76.094
ARM Processor	10.38	13%(26X16384)	8.50	36.094
FPGA SoC	12.12	4% (8X16384)	5.40	18.953
Run time reconfiguration	13.02	8% (16X16384)	1.81	10.62

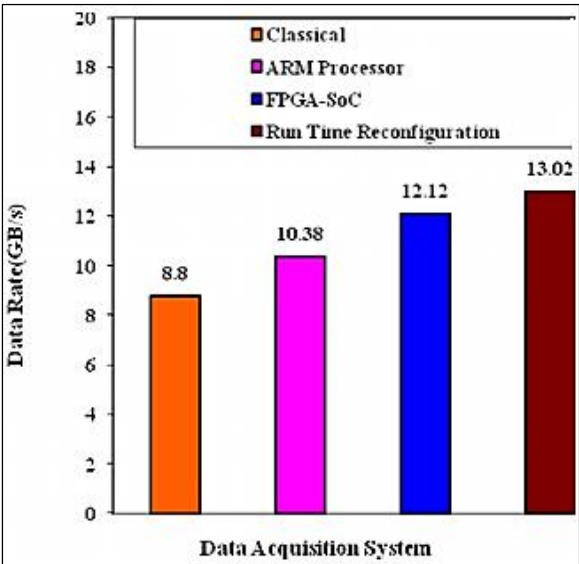

Fig 7: Comparison of data rate speed for various proposed DAQ system

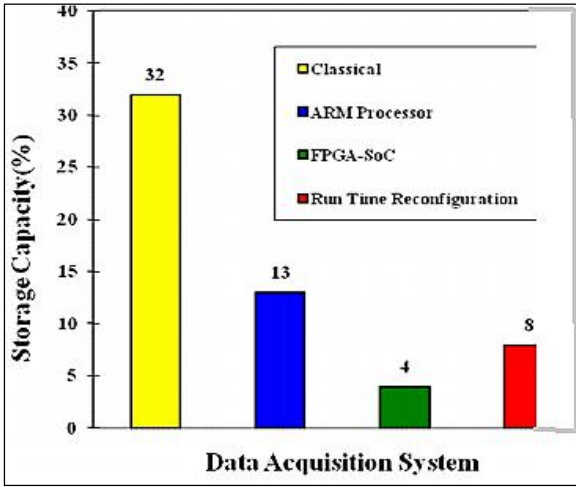

Fig 8: Comparison of storage capacity for various proposed DAQ system

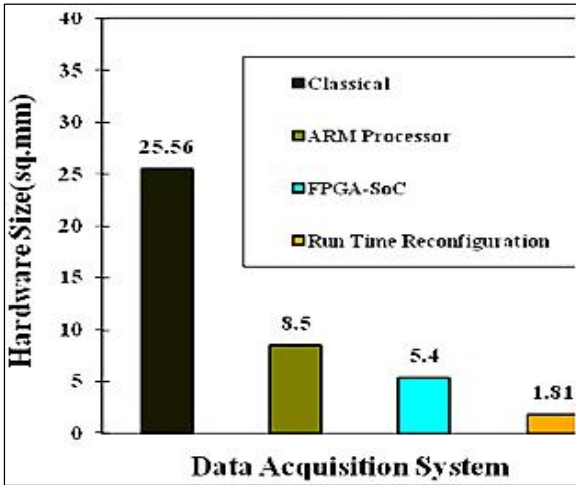

Fig 9: Comparison of hardware size for various proposed DAQ system

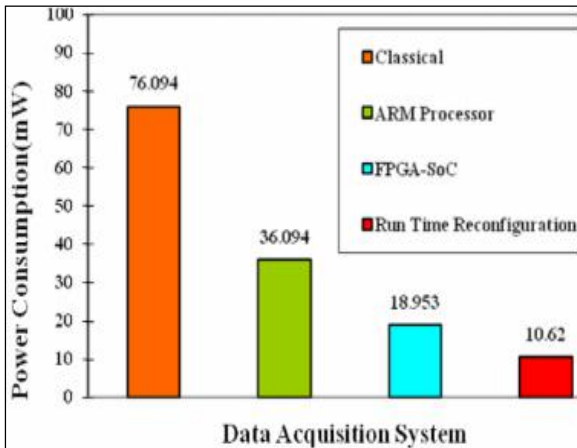

Fig 10: Comparison of power consumption for various proposed DAQ system

References

1. Bogdan Croitoru, Loredana Boca, Adrian Tulbure. 'The Management of Wireless Real-Time Data Acquisition Processes using Virtual Instruments', proceedings of the International Conference on Automation, Quality and Testing, Robotics, 2010, 1-6.
2. Brett Stanley Feero, Partha Pratim Pande. 'Networks-On-Chip in a Three-Dimensional Environment: A Performance Evaluation', IEEE Transactions on Computer. 2009; 58(1):32-45.
3. Bruno Santos Pimentel, Joao Hilario de Avila Valgas Filho & Rodrigo Lacerda Campos, 'A FPGA implementation of a DCT-Based Digital Electrocardiographic Signal Compression Device', Proceedings of Fourteenth Symposium on Integrated Circuits and System Design, 2001, 44-49.
4. Campelo JC, Yuste P, Gil PJ, Serrano JJ. 'DICOS: A Real-Time Distributed Industrial Control System for Embedded Applications', Control Engineering Practice, 2001, 439-447.
5. Cardoso JM, Simões JB, Correia CMBA. 'A high-performance reconfigurable hardware platform for digital pulse processing', IEEE Transactions on Nuclear Science. 2004; 51(3):921-925.
6. Chang W, Wu Y, Chiu C. 'Development of a Web-based Remote Load Supervision and Control System', Electrical Power and Energy Systems 28, Elsevier Limited, 2006, 401-407.

7. Changting Wang & Robert X Gao, 'A Virtual Instrumentation System for Integrated Bearing Condition Monitoring', IEEE Transactions on Instrumentation and Measurement. 2000; 49(2):325-332.
8. Chaoui H, Yagoub MCE, Sicard P. FPGA implementation of a fuzzy controller for neural network based adaptive control of a flexible joint with hard nonlinearities', Proceedings of IEEE International Symposium on Industrial Electrons. 2006; 4:3124-3129.
9. Chen Lin. Research on Voltage Acquisition System Based on Modbus Industrial Bus and Single Chip, Proceedings of International Conference on Signal Processing Systems, 2009, 585-588.
10. Chen R, He ZX, Qiu J, He L. Distributed data acquisition unit based on GPS and ZigBee for electromagnetic exploration', Proceedings of the Instrumentation and Measurement Technology Conference (I2MTC), ed. Austin, TX, 2010, 981-985.
11. Chixiang Ma, Hao Cao, Ping Lin. A Low Power Low Cost Design of Primary Synchronisation Signal Detection', IEEE Transactions on VLSI. 2012; 20(7):1161-1166.
12. Custódio FM Loureiro, Carlos MBA Correia. Innovative Modular High-Speed Data-Acquisition Architecture, IEEE Transactions on Nuclear Science. 2002; 49(3):858-860.
13. Dan Li, Chongquan Zhong, Xiaofeng Yuan, Zhang Li. Study on Embedded Equipment Web Monitoring and Control Based on Industrial Ethernet', Proceedings of Sixth World Congress on Intelligent Control and Automation, ed. Dalian, China, 2006, 4600-4603.
14. Daogang Peng, Hao Zhang, Jiannian Weng, Hui Li, Fei Xia. Research and Design of Embedded Data Acquisition and Monitoring System Based on Power PC and CAN bus', Proceedings of the Eighth World Congress on Intelligent Control and Automation, 2010, 4147-4151.
15. Daogang Peng, Hao Zhang, Kai Zhang, Hui Li, Fei Xia. Research and Development of the Remote I/O Data Acquisition System Based on Embedded ARM Platform', Proceedings of IEEE International Conference on Electronic Computer Technology, 2009, 341-344.

Chapter - 3

Programming Logic Controllers (PLC's)

Authors

Prof. Natesh CP

Assistant Professor, Department of Mechanical Engineering,
Channabasaveshwara Institute of Technology, Gubbi,
Tumakuru, Karnataka, India

Prof. Naveen CR

Assistant Professor, Department of Mechanical Engineering,
Srinivas Institute of Technology, Valachil, Mangaluru,
Karnataka, India

Prof. Santhosh Kumar TC

Assistant Professor, Department of Mechanical Engineering
BGSIT, BG Nagara, Mandya, Karnataka, India

Chapter - 3

Programming Logic Controllers (PLC's)

Prof. Natesh CP, Prof. Naveen CR and Prof. Santhosh Kumar TC

Abstract

As the need of automation increases significantly, a control system needs to be easily programmable, flexible, reliable and cost effective. In this chapter review on the programming and applications of Programmable Logic Controller (PLC) in our current market is discussed. Studied on the ladder logic programming, principle of operation and selection of PLC's in engineering studies, industrial control applications and monitoring of plants are reviewed in this chapter. PLC's do have its own limitations, but studies indicate that PLC's have more benefits than limitations. PLC's are used in industrial automation to solve complex problems.

Keywords: PLC, ladder logic, automation, memory, switches

Introduction

In industry control applications are carried out by specialized devices for interfacing with analog and digital devices with restricted instruction sets using PLC. PLC's offer more flexibility in developing complex control algorithms and is best suited for industrial monitoring and control, in production environment. They are usually programmed with ladder logic, which is graphical method of laying out the connectivity and logic between system inputs and outputs. Apart from being flexible and easy to program, they are rugged and immersed relatively to external interferences.

1. PLC's structure

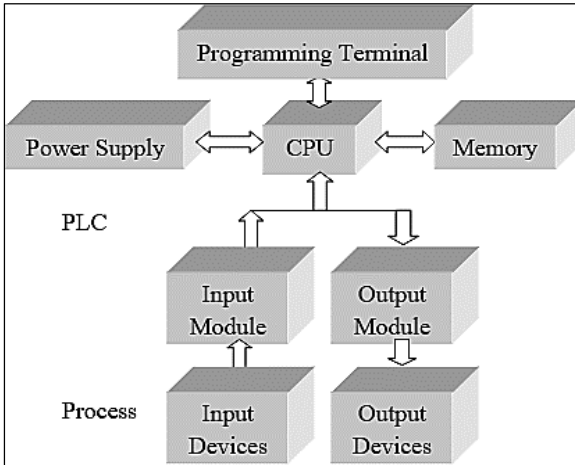

PLC's structure flow chart

The structure of a PLC can be dividing into four parts they are,

- Input/output modules.
- CPU.
- Memory.
- Programming Terminal.

A PLC operates by examining the input signals from a process and carrying out logic instructions (which have been programmed to its memory) on these input signals, producing output signals to drive process equipment (or) machinery. Standard interfaces built into PLC allow them to be directly connected to process actuators and transducers without the need for intermediate circuitry or relays. PLC's requires shorter installation and commissioning times than do hard wired systems. Although PLC's are similar to 'conventional' computers in term of hardware technology, they have specific features suited for industrial control.

- Rugged, noise immune equipment.
- Modular plug-in in construction, allowing easy replacement.
- Standard input/output connections and signal levels.
- Easily understood programming language.
- Competitive in both cost and space occupied with relay and solid-state logic systems.

2. Principle operation of PLC

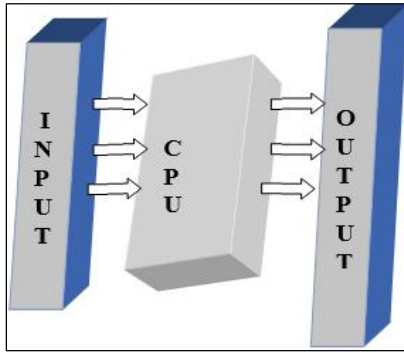

The principal operation of a PLC is relatively simple the input/output system is physically connected to the fields devices that are encountered in the machine (or) that are used in the control of a process. PLC's are used for continuously monitoring the input values from sensors and produces the outputs for the operation of actuators based on the program.



Basic Structure of PLC (Image)

3. Ladder logic

- Ladder logic was originally a written method to document the design and construction of relay racks as used in manufacturing and process control.
- Ladder logic as evolved into a programming language that represents a program by a graphical diagram based on the circuit diagram of relay logic hardware.
- Ladder logic on the circuit diagram of relay logic hardware.
- Ladder logic is used to develop software for PLC's used in industrial control applications.

3.1 Rung input (checkers-contacts)

-[]- Normally open contact, closed whenever its corresponding coil (or) an input which controls it is energized (open contact at rest)

$$= \text{True} = 1 \quad \boxed{\text{NO}}$$

-[\]- Normally closed (not) contact, closed whenever its corresponding coils (or) an input which controls it is not energized (closed contact at rest).

$$= \text{False} = 0 \quad \boxed{\text{NC}}$$

3.2 Rung output (actuators-coils)

-()- Normally inactive coil, energized whenever its rung is closed (Inactive at rest).

-(\)- Normally active (not), energized whenever its rung is open (Active at rest).

Logical and

|-----[]-----[]-----()-----|

Key Switch1 Key Switch2 Door Motor

The above realizes the function:

Door Motor = Key Switch 1 AND Key Switch 2

Logical AND with NOT

|-----[]-----[\]-----()-----|

Close Door Obstruction Door Motor

The above realizes the function:

Door Motor = Close Door AND NOT Obstruction.

Logical OR

|-----|-----[\]-----|---()-----|

| Exterior Unlock | Unlock

|-----[]-----|

Interior Unlock

The above realizes the function:

Unlock = Interior Unlock OR Exterior Unlock

Industrial STOP/START

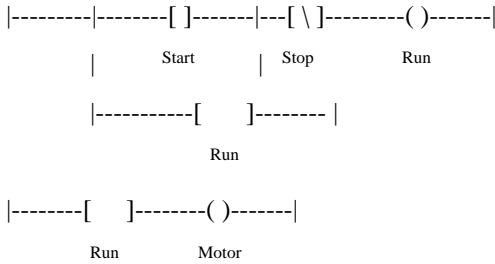

The above realizes the function:

$$\text{Run} = (\text{Start OR Run}) \text{ AND } (\text{NOT Stop})$$

Complex logic

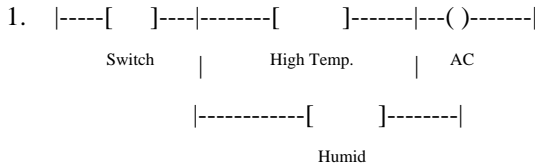

$$\text{AC} = \text{Switch AND (High Temp. or Humid)}$$

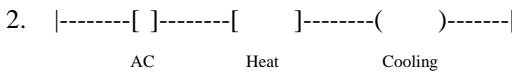

$$\text{Cooling} = \text{AC AND (Not Heat)}$$

4. PLC Operation

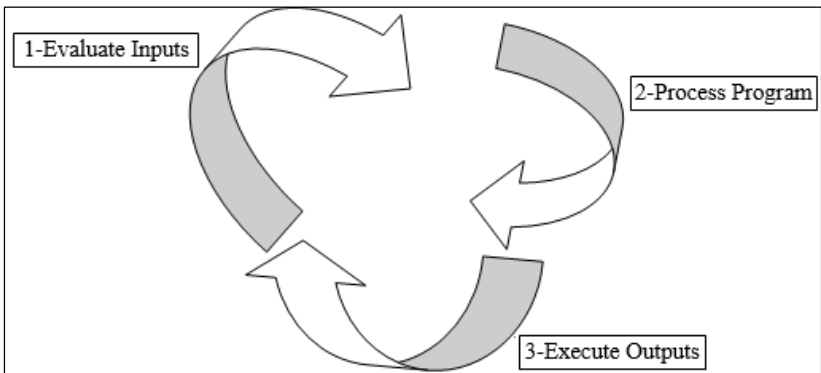

PLC operation stages

A PLC Operates in cycle manner. It evaluates the inputs, processes the program and finally executes the output. One cycle is called as scan. The time takes to complete a scan is called scan time and is expressed in ms (milliseconds).

4.1 PLC memory structure

- Bits-1(True) or (False)
- Byte-8 bits
- Words-16 bits (2 bytes)
- Double words-32 bits (4 bytes, 2 words)

5. Programming and concept of ladder diagram

In this segment, we will see how PLCs are incorporated to control various activities in an industry. In this illustration we have a conveyor belt run with two motors at its ends, three different stations to perform various activities like painting of vehicle body or fitting of any component in chassis etc along with two switches to run conveyer. Below figure shows the photograph of a conveyor belt system. The PLC is of “Bull 1764 Micrologix 1500 LSP Series C” which can be controlled by a Graphical User Interface “RS Logic 500 Starter”.

5.1 PLC structure for ladder logic programming

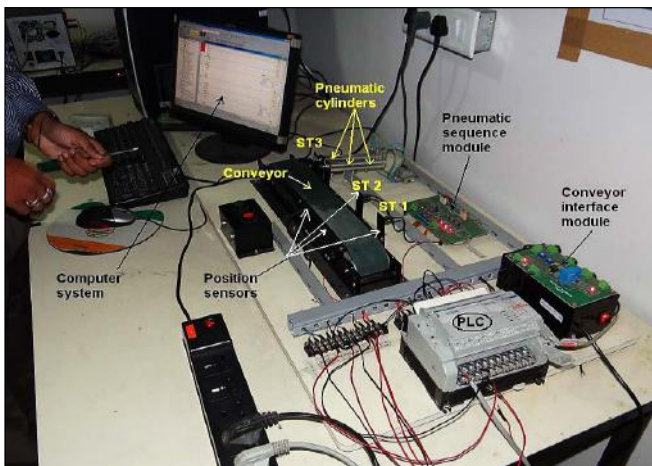
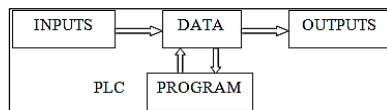

PLC controlled conveyor belt system

Inputs: Are field devices such as button, switches are used to decide when and how the machine will operate.

Outputs: Are field devices such as Relays, Motors, Valves, and Lamps which cause the machine to operate and provide feedback to the machine operator.

Data/Memory: I/P and O/P declared and allocated to memory locations.

Program/Memory: Is where ladder logic is stored and processed.

6. Concept of latching

A latch is like a sticky switch-when pushed it will turn on, but stick in place, it must be pulled to release it and turn it off. A latch in ladder logic uses one instruction to a latch, and a second instruction to unlatch, as shown in figure below.

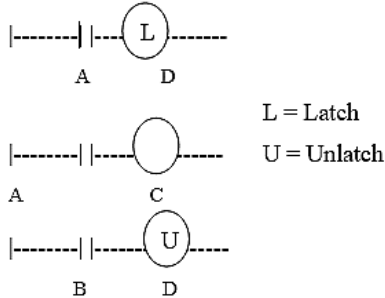

In industrial applications, it is required to use various sensors to control the operations of systems and processes using PLCs. Below figure shows a typical program to operate an electric motor and a pneumatic cylinder with the help of some sensors such pneumatic proximity switch. To control a Mechatronics system we need to combine various mechanical and electrical input and output devices and to operate them in a sequential manner. Consider a prototype of industrial assembly line with 3 stations as shown in PLC controlled conveyor belt system figure at first station ST1, the sensor identifies an object (finished product) on the conveyer belt and sends a signal to the controller. Controller processes this information and actuates the electric motor to run the conveyer belt. Second Station ST2: It is allotted for the inspection of the finished product or object. At ST2, conveyer belt stops. In case any fault diagnosed by the inspection system, the product will be taken away by the pneumatic actuators placed at Station 3, ST3.

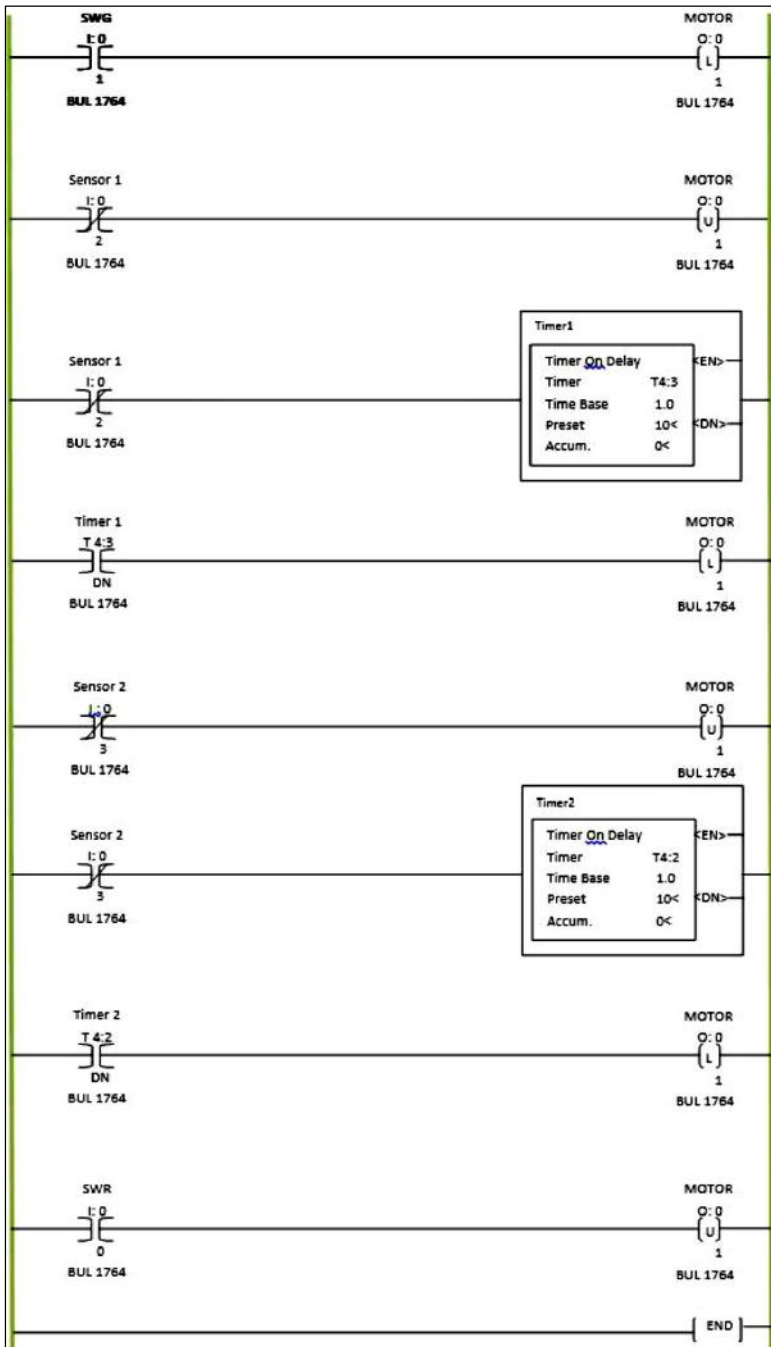

7. PLC selection

System requirements

- The starting point in determining any solution must be to understand what is to be achieved.
- The program design starts with breaking down the task into a number of simple understandable elements, each of which can be easily described.

Application requirements

- Input and output device requirements. After determining the operation of the system, the next step is to determine what input and output devices the system requires.
- List the function required and identifies a specific type of device.
- The need for special operations in addition to discrete (On/Off) logic.
- List the advanced functions required beside simple discrete logic.

Electrical requirements

The electrical requirements for inputs, outputs, and system power; when determining the electrical requirements of a system, consider these points:

- Incoming power (power for the control system).
- Input device voltage.

Speed of operation

How fast the control system must operate (speed of operation).

When determining speed of operation, consider these points:

- How fast does the process occur or machine operate?
- Are there “time critical” operations or events that must be detected?
- In what time frame must the fastest action occur (input device detection to output device activation)?
 - Does the control system need to count pulses from an encoder or flow-meter and respond quickly?

Communication

Communication involves sharing application data or status with another electronic device, such as a computer or a monitor in an operator’s station. Communication can take place locally through a twisted-pair wire or remotely via telephone or radio modem.

Operator interface

In order to convey information about machine or process status, or to allow an operator to input data, many applications require operator interfaces. Traditional operator interfaces include push buttons, pilot lights and LED numeric display. Electronic operator interface devices display messages about machine status in descriptive text, display part count and track alarms. Also, they can be used for data input.

Physical environment

The physical environment in which the control system will be located considers the environment where the control system will be located. In harsh environments, house the control system in an appropriate IP-rated enclosure. Remember to consider accessibility for maintenance, trouble shooting or reprogramming.

8. Applications of PLC in industries

- Glass Industries
- Paper Industries
- Cement Manufacturing
- Robotic arm in car manufacturing
- Air compressors
- Airport runway lighting control
- Traffic signal control
- Textile equipments
- Vacuum pump system

9. Advantages of PLC

- Small physical size & shorter project time
- Cost effective for controlling complex system
- Reliability
- Less and simple wiring
- Faster response
- Remote control capability
- More flexibility
- Ease of maintenance

10. Disadvantages of PLC

- Fixed circuit operation.
- PLCs manufacturers offer only closed loop architecture.
- PLCs are propitiatory.
- Number of optional modules must be added to maximize flexibility and performance.

11. References

1. Bolton W. Programmable Logic Controllers, Pearson Publications, Seventh Edition, 2018.
2. PLC Applications, <http://www.entertron.com/application.htm>.
3. PLC History, http://www.machine-information-systems.com/PLC_History.html.
4. PLC Manual, Basic guide to PLC, <http://www.plcmanual.com/plc-programming>.

Chapter - 4

An Overview of Machine Learning and Its Engineering Applications

Authors

P. Kamalakar

Associate Professor, Department of EEE, Malla Reddy Engineering College (Autonomous), Maisammaguda, Hyderabad, Telangana, India

S. Bharathi

Assistant Professor, Department of EEE, Malla Reddy Engineering College (Autonomous), Maisammaguda, Hyderabad, Telangana, India

G. Ravi Kishore

Associate Professor, Department of ECE, Vidya Jyothi Institute of Technology, Hyderabad, Telangana, India

S. Santhipriya

Assistant Professor, Department of ECE, Vidya Jyothi Institute of Technology, Hyderabad, Telangana, India

Chapter - 4

An Overview of Machine Learning and Its Engineering Applications

P. Kamalakar, S. Bharathi, G. Ravi Kishore and S. Santhipriya

Abstract

There has been a lot going on in the field of Artificial Intelligence and Machine Learning. These new approaches towards problem solving in both real-world practical and theoretical scenarios have opened doors for limitless improvements (and opportunities) in many domains ranging from finance, biology, space-technology and so on. Many eminent researchers in the new field believe that the field of electrical engineering is no exception. With this thread to be specific, we are looking for some motivation for doing a thesis in this domain of AI & EPS. AI techniques & machine learning methods are used to solve many real-time related problems in Electronics Engineering. They are used (through learning and training) to model a complex system where analytical methods fail, to construct robust controllers, and to solve for optimal solutions.

1. Introduction

Machine mastering is a branch of artificial talent that pursuits at enabling machines to function their jobs skillfully by means of the use of shrewd software. The statistical getting to know techniques represent the backbone of smart software that is used to boost computer intelligence. Because computing device learning algorithms require statistics to learn, the self-discipline must have connection with the self-discipline of database. Similarly, there are acquainted phrases such as Knowledge Discovery from Data (KDD), data mining, and sample recognition. One wonders how to view the huge picture in which such connection is illustrated.

There are some duties that people operate easily or with some efforts, however we are unable to provide an explanation for how we perform them. For example, we can recognize the speech of our pals besides a lot difficulty. If we are asked how we apprehend the voices, the reply is very difficult for us to explain. Because of the lack of perception of such phenomenon (speech

awareness in this case), we can't craft algorithms for such scenarios. Machine studying algorithms are useful in bridging this hole of understanding. The thought is very simple. We are now not targeting to recognize the underlying strategies that assist us learn. We write pc packages that will make machines examine and enable them to function tasks, such as prediction.

The purpose of studying is to construct a mannequin that takes the input and produces the preferred result. Sometimes, we can understand the model, whereas, at different times, it can also be like a black box for us, the working of which can't be intuitively explained. The mannequin can be regarded as an approximation of the procedure we desire machines to mimic. In such a situation, it is feasible that we reap blunders for some input, but most of the time, the model affords right answers. Hence, some other measure of performance (besides performance of metrics of pace and reminiscence usage) of a computing device getting to know algorithm will be the accuracy of results.

The issue will be in addition clarified when the issue will be discussed with examples at their applicable places. However, before the discussion, a few extensively used terminologies in the computing device getting to know or information mining neighborhood will be mentioned as a prerequisite to respect the examples of laptop learning applications. Figure 1.1 depicts 4 computer learning methods and describes quickly the nature of statistics they require.

1.1 Supervised learning

In supervised learning, the target is to infer a feature or mapping from training records that is labeled. The education data consist of enter vector X and output vector Y of labels or tags. A label or tag from vector Y is the explanation of its respective enter example from enter vector X . Together they form a coaching example. In other words, education data comprises education examples. If the labeling does no longer exist for input vector X , then X is unlabeled data. Why such mastering is called supervised learning? The output vector Y consists of labels for every coaching instance current in the training data. These labels for output vector are furnished through the supervisor. Often, these supervisors are humans, but machines can also be used for such labeling. Human judgments are more pricey than machines, but the higher error fees in records labeled via machines suggest superiority of human judgment. The different machine learning techniques are shown in Figure 1. However, in some cases, machines can be used for dependable labeling.

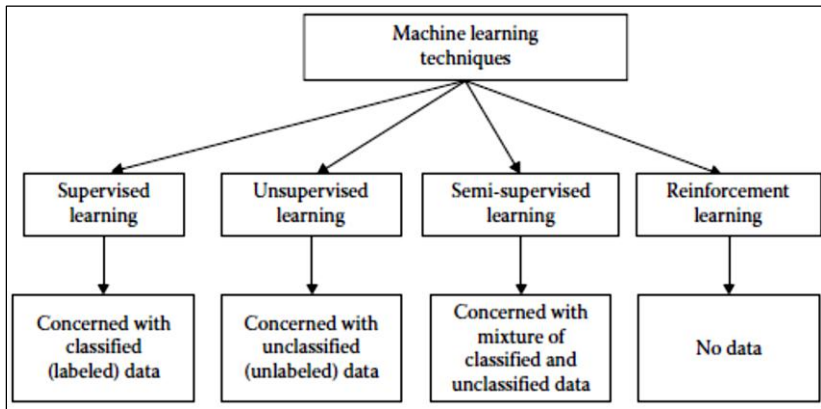

Fig 1: Machine learning techniques

Example Table 1. demonstrates five unlabeled data examples that can be labeled primarily based on exceptional criteria. The 2d column of the desk titled, “Example judgment for labeling” expresses possible criterion for each data example. The 0.33 column describes feasible labels after the software of judgment. The fourth column informs which actor can take the role of the supervisor. In all first 4 instances described in Table 1, machines can be used, but their low accuracy prices make their utilization questionable. Sentiment analysis, photograph recognition, and speech detection applied sciences have made growth in past three a long time however there is nonetheless a lot of room for improvement before we can equate them with humans’ performance. In the fifth case of tumor detection, even ordinary human beings cannot label the X-ray data, and highly-priced experts’ offerings are required for such labeling. Two organizations or classes of algorithms come beneath the umbrella of supervised learning. They are 1. Regression 2 Classification.

Table 1: Unlabeled Data Examples along with Labeling Issues

Unlabeled data example	Example judgment for labeling	Possible labels	Possible supervisor
Tweet	Sentiment of the tweet	Positive/negative	Human/machine
Photo	Contains house and car	Yes/No	Human/machine
Audio recording	The word football is uttered	Yes/No	Human/machine
Video	Are weapons used in the video?	Violent/nonviolent	Human/machine
X-ray	Tumor presence in X-ray	Present/absent	Experts/machine

1.2 Unsupervised learning

In unsupervised learning, we lack supervisors or coaching data. In other words, all what we have is unlabeled data. The idea is to find a hidden structure

in this data. There can be a quantity of motives for the data no longer having a label. It can be due to unavailability of dollars to pay for guide labeling or the inherent nature of the records itself. With several facts collection devices, now information is gathered at an extraordinary rate. The variety, velocity, and the extent are the dimensions in which Big Data is viewed and judged. To get something from this statistics besides the supervisor is important. This is the mission for today's machine studying practitioner.

1.3 Semi-supervised learning

In this type of learning, the given statistics are a mixture of classified and unclassified data. This mixture of labeled and unlabeled data is used to generate an terrific model for the classification of data. In most of the situations, labeled data is scarce and unlabeled records is in abundance (as mentioned previously in unsupervised mastering description). The goal of semi-supervised classification is to learn a mannequin that will predict lessons of future test data higher than that from the mannequin generated through using the labeled information alone. The way we examine is comparable to the procedure of semi-supervised learning.

A toddler is provided with,

1. Unlabeled statistics provided by using the environment. The surroundings of a infant are full of unlabeled statistics in the beginning.
2. Labeled facts from the supervisor. For example, a father teaches his teenagers about the names (labels) of objects via pointing toward them and uttering their names.

1.4 Reinforcement learning

The reinforcement mastering approach aims at using observations gathered from the interaction with the surroundings to take movements that would maximize the reward or limit the risk. In order to produce shrewd programs (also referred to as agents), reinforcement mastering goes through the following steps:

1. Input country is observed through the agent.
2. Decision making feature is used to make the agent perform an action. three After the action is performed, the agent receives reward or reinforcement from the environment. Four the state-action pair information about the reward is stored. Using the saved information, policy for specific kingdom in terms of action can be fine-tuned, as a result helping in foremost decision making for our agent.

1.5 Validation and Evaluation

Assessing whether or not the model learnt from computer studying algorithm is properly or not, desires each validation and evaluation. If one claims that for a unique training data the characteristic fits perfectly, then for the computing device mastering community, this declare is not enough. They will straight away ask about the overall performance of characteristic on testing data.

A function becoming perfectly on education records desires to be examined. Sometimes, it is the phenomenon of overfitting that will supply great overall performance on education data, and when yet-unseen labeled information will be used to check them, they will fail miserably.

2. Applications of machine learning algorithms

Though the idea of a machine making decisions on its own and thinking independently may sound almost like a work of fiction, machine learning is actually more common than many people may expect. The general public can find elements of it in many areas of daily life. For instance, when people finish binge-watching a favorite television series, Netflix may suggest a new series that they might enjoy based on previous programs that were watched. This is an example of machine learning in a very practical application. Netflix uses an algorithm that can find common themes in a person's previous preferences—such as a tendency toward dark comedies and then extrapolates those preferences to find other television series or films that will likely suit that particular taste in entertainment. While these are very useful applications of machine learning for the average person, the field is much more than shopping and entertainment. These algorithms are used in public safety, agriculture, wearable medical devices and even self-driving cars.

Computer vision is also an important application of this field. This area of study works to enable computers to act as the human vision system does, which in simple terms is to gather information from images and translate it to understanding. For example, using computer vision, a drone flying over a field could identify portions of the crop that look diseased and alert the farmer to the problem.

2.1 Computer-aided diagnosis

Pattern awareness algorithms used in computer-aided diagnosis can help medical practitioner in decoding medical images in a exceedingly short period. Medical snap shots from different scientific exams such as X-rays, MRI and ultrasound are the sources of facts describing a patient's condition. The

responsibility of a radiologist is to analyze and evaluate the output of these clinical checks that are in the structure of a digital image. The short time constraint requires that the radiologist be assisted through machine.

Computer-aided diagnosis uses pattern focus techniques from machine learning to pick out suspicious constructions in the image. How does an algorithm trap suspicious structure? Supervised learning is executed to function this task. Few thousand labeled images are given to the computing device getting to know algorithm, such as Bayesian classifier, artificial neural network, radial basis feature network, and help vector machine. The resulting classifier is expected to classify new medical images correctly. Mistakes in diagnosis by way of the machine learning algorithm an deliver catastrophe for a family.

The following are two such examples:

1. Suppose our classifier detects breast cancer in a patient who really had no such disease. The results obtained by the classifier will create dangerous psychological conditions for the patient. In order to affirm the result of the classifier, further checks can result in economic losses for the patient.
2. Suppose our classifier does not observe breast most cancers in patient who sincerely has such a disease. This will lead to incorrect clinical cure and can threaten the existence of the patient in close to or a long way future. In order to keep away from such mistakes, the complete substitution of health practitioner with technology is not recommended.

The position of technology should be supportive. It has to be the doctor (generally a radiologist) who have to take the duty of the final interpretation of medical image. Computer-aided prognosis is assisting clinical doctors/radiologists in the analysis of quantity of health problems.

Few examples are as follows:

- Pathological brain detection
- Breast cancer
- Lung cancer
- Colon cancer
- Prostate cancer
- Bone metastases
- Coronary artery disease

- Congenital heart defect
- Alzheimer’s disease

2.2 Driverless cars

Autonomous cars with no drivers are additionally one of the applications where car imaginative and prescient is absolutely made viable by advancement in the computer vision technology. In the industry, it is clear that there is ongoing opposition to manufacture driverless cars walking on the roads as early as possible. According to the BBC report titled Toyota promises driverless motors on roads through 2020, one-of-a-kind rivals are on the bandwagon and saying their objectives for driverless cars. The article states:

Toyota is the latest car corporation to push forward with plans for an self-reliant vehicle, presenting fresh competition to Silicon Valley agencies such as Google, Cruise and Tesla. Last week, General Motors said it used to be offering driverless rides to workers at its lookup and development facility in Warren, Michigan. Nissan has promised to put an automated vehicle on Japan’s roads as early as 2016. However, Google is already testing its self-driving cars on US town streets. And Tesla chief executive Elon Musk stated in July his corporation used to be “almost ready” to make its vehicles go driverless on foremost roads and parallel-park themselves.



Fig 2: Toyota tested its self-driving Highway Teammate car on a public road

How these automobiles will accomplish this task? BBC article states the narrative of Toyota in following words: According to Toyota, the vehicle “uses more than one external sensors to recognize close by vehicles and hazards, and selects terrific routes and lanes depending on the destination”. Based on these information inputs, it ““automatically operates the steering wheel, accelerator and brakes’ to power in a good deal the same way as a character would drive”. (Figure 2).

The functions that are and will be the use of computer vision- related applied sciences are very touchy in nature. A driverless automobile accident can result in a tragedy for family or families. Similarly, some other very touchy region is the usage of pc vision science in drones. The drones that are used in combat can kill harmless humans if algorithms behind the imaginative and prescient misbehave.

2.3 Face recognition and security

In Figure 3, Images from clever telephones and CCTV cameras are now produced at an unheard of rate. A problem pertinent to face recognition is to associate the face image to its respective identity. Building a classifier for this venture is no longer a trivial job, because there are too many classes concerned with multiple image-related problems. Face awareness can assist security agencies to use a large amount of records from exclusive sources to automatically locate what is very hard for people to do manually.

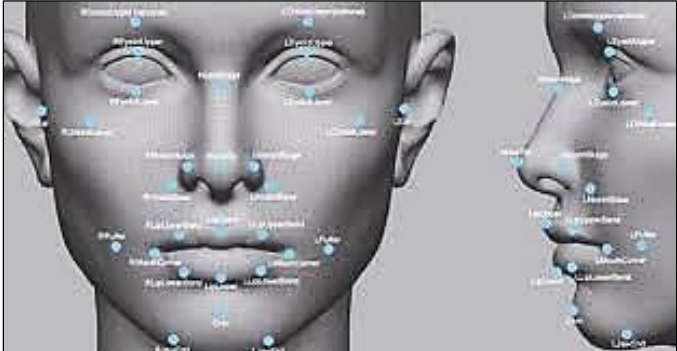

Fig 3: Face recognition

2.4 Speech recognition

The discipline of speech recognition goals to increase methodologies and technologies that enable computers to recognize and translate spoken language into text. Stenography (writing in shorthand) is no longer required. Automatic transcription of speech into textual content has determined its way in areas such as video captioning and court docket reporting. This technology can assist people with disabilities. With the passage of time, the accuracy of speech focus engines is increasing. There is no doubt that voice-controlled packages such as Apple’s Siri, Google Now, Amazon’s Alexa, and Microsoft’s Cortana do now not always understand our speech, however things are probably to be improved in the near future.

2.5 Communication

Different from the aforementioned ML applications, the development of communications has vastly relied on theories and models, from information theory to channel modelling. These traditional approaches are showing serious limitations, especially in view of the increased complexity of communication networks. Therefore, research on ML applied to communications, especially to wireless communications, is currently experiencing an incredible boom.

This collection of Best Readings focuses on ML in the physical and medium access control (MAC) layer of communication networks. ML can be used to improve each individual (traditional) component of a communication system, or to jointly optimize the entire transmitter or receiver. Therefore, after introducing some popular textbooks, tutorials, and special issues in this collection, we divide the technical papers into the following six areas:

- Signal detection.
- Channel encoding and decoding.
- Channel estimation, prediction, and compression.
- End-to-end communications.
- Resource allocation.
- Selected topics.

Even if ML in communications is still in its infancy, we believe that a growing number of researchers will be dedicated to the related studies and ML will greatly change the way of communication system design in the near future.

3. Engineering the next wave of artificial intelligence

Automating tasks through machine learning models, such as artificial neural networks or decision trees, results in systems that can often make decisions and predictions more accurately than humans can. As these systems continue to evolve, it is likely they will fundamentally transform our ability to leverage information at scale.

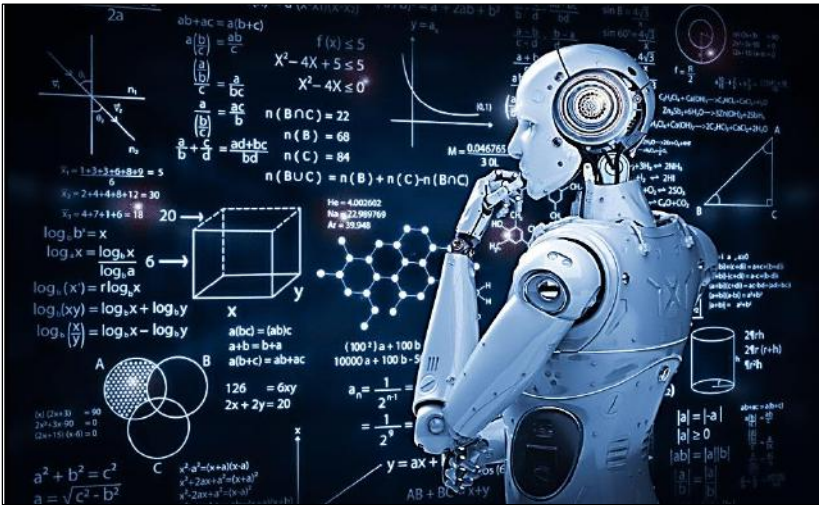

Fig 4: Machine learning for next generation

But the tasks involved in implementing machine learning algorithms for an ever-growing number of diverse applications, from agriculture to telecommunications, are highly resource-intensive. It takes a robust, customized network architecture to optimize the performance of deep learning algorithms that may rely on billions of training examples. Furthermore, once an algorithm is trained, it may be required to continue processing an ever-growing volume of data-some of the sensors currently embedded in autonomous vehicles are capable of generating 19 terabytes of data per hour.

In Figure 4, Electrical and computer engineers play a vital part in enabling AI's ongoing evolution by developing computer and communications systems that match the growing power of artificial neural networks. Creating hardware that's optimized to perform machine learning tasks at high speed and efficiency opens the door for new possibilities in autonomous vehicle guidance, customer relationship management, fraud detection and countless other applications.

4. Conclusion

In the growing field of machine learning, engineers play an important role. Professionals with a background in electrical engineering or software engineering are usually equipped with the knowledge and skill set needed to contribute to this new field in a meaningful way.

To be successful in the field of machine learning, you should develop the following qualifications and skills:

- Probability and statistics.
- Applied math and algorithms.
- Coding languages.
- Advanced signal processing techniques.

This role is not to be confused of that of a data analyst. Though the positions are similar, the goal of a data analyst is typically to gather and evaluate information-a process completed by humans-to create usable results. Machine learning engineers typically focus more on giving computers the ability to process that information on their own. However, in the field of machine learning the responsibilities of the positions can overlap.

5. References

1. Guthrie. Looking backwards, looking forwards: SAS, data mining and machine learning, 2014. <http://blogs.sas.com/content/subconsciousmusings/2014/08/22/looking-backwards-looking-forwards-sas-data-mining-and-machine-learning/>.
2. Mitchell TM. The Discipline of Machine Learning, Machine Learning Department technical report CMU-ML-06-108. Pittsburgh, PA: Carnegie Mellon University, 2006.
3. <https://www.comsoc.org/publications/best-readings/machine-learning-communications>
4. <https://online.egr.msu.edu/articles/ai-machine-learning-electrical-computer-engineering-applications>.
5. United States Postal Service. <https://about.usps.com/who-weare/postal-facts/innovation-technologies.htm> (accessed October 4, 2015).
6. Vinyals O, Le QV. A neural conversational model, Proceedings of the 31st International Conference in Machine Learning, arXiv:1506.05869v3, 2015, 37.
7. <https://engineeringonline.ucr.edu/blog/an-engineers-role-in-machine-learning/>

Chapter - 5
**An Automatic Smart Energy Meter Reading
System for Consumer Appliances**

Authors

Addanki Purna Ramesh

Professor, Department of ECE, Vishnu Institute of Technology,
Bhimavaram, Andhra Pradesh, India

Narendrakumar Chinta

Associate Professor, Department of EEE, Malla Reddy
Engineering College (Autonomous), Maisammaguda,
Secunderabad, Telangana, India

Suman Tenali

Research Scholar, Sri Satya Sai University of Technology &
Medical Sciences, Sehore, Madhya Pradesh, India

Sravanthi Kantamaneni

Assistant Professor, Department of ECE, R.V.R. College of
Engineering, Guntur, Andhra Pradesh, India

Chapter - 5

An Automatic Smart Energy Meter Reading System for Consumer Appliances

Addanki Purna Ramesh, Narendrakumar Chinta, Suman Tenali and Sravanthi Kantamaneni

Abstract

Due to rapid increase in human population and the human's dependency towards electrical energy, the demand of electricity has increased, causing deficit of electrical energy during peak hours. As per the report of CEA, India, the gap between the electrical energy supply and the energy demand in July-2014 is -3.9% (MW). Accurate metering, detection of illegal activities and implementation of proper tariff and billing system would manage the consumption of electrical energy. Collecting meter reading is one of the most difficult procedures in billing. The traditional electrical energy meter data collection is such that a person from the utility provider visits the consumer sites periodically to note the meter reading. This procedure has lot of drawbacks such as, it is time consuming, tiresome and requires more human resource and human error and even corruption is probable. The process may be interrupted due to bad weather conditions, also if the consumer is not available, the billing will be pending and human operator needs to revisit. India is facing energy deficit during peak hours. Low voltage during peak hours has been reported as a major power quality issue. Load shedding is a common power management practice followed by the utility providers. Energy conservation has great significance in this scenario of increasing electrical energy demand. An Automatic Meter Reading (AMR) system equipped with advanced features like two-way communication, Time-Of-Day (TOD) tariff, etc. will address the problems of manual collection of meter data, energy deficit during peak hours and opens a channel for the consumers to participate in energy conservation.

1. Introduction

With development in technologies in the fields of communication and information technology, a wide variety of AMR and smart meters has been developed. A smart meter is an AMR with two-way communication

infrastructure. Smart meters has been designed for various features like remote monitoring of energy consumptions, remote turn ON/OFF power supply, remote detection of energy theft, With time varying pricing system, remote fault detection, capable of monitoring power quality etc. Developments in information management and remote monitoring technology can play a vital role in energy management. Smart meter reading co-operate both utilities and consumers in eliminated, integration of an apt tariff system with the smart meter reading data reduces the power management, giving them detailed information about power consumption. Although the implementation cost of Smart meters systems are high, their implementation will increase the revenue of the utility provider because of the following reasons, the working status of the consumer end meters can be identified remotely, eliminate the corruption by the human operator or the consumer and labour of meter reading is consumption of electricity during peak hours etc. Smart meters perceived to be a necessity rather than luxury in India.

A smart meter is an electronic device that records consumption of electric energy in intervals of an hour or less and communicates that information at least daily back to the utility for monitoring and billing. Smart meters enable two-way communication between the meter and the central system. Unlike home energy monitors, smart meters can gather data for remote reporting. Such an advanced metering infrastructure (AMI) differs from traditional automatic meter reading (AMR) in that it enables two-way communications with the meter. Communications from the meter to the network can be done via fixed wired connections (such as power line communications) or via wireless. In using wireless, one can opt for cellular communications (which can be expensive), Wi-Fi (readily available), wireless ad hoc networks over Wi-Fi, wireless mesh networks, low power long range wireless (LORA), ZigBee (low power low data rate wireless), Wi-SUN (Smart Utility Networks), etc.

The term Smart Meter often refers to an electricity meter, but it also may mean a device measuring natural gas or water consumption. Similar meters, usually referred to as interval or time-of-use meters, have existed for years, but "Smart Meters" usually involve real-time or near real-time sensors, power outage notification and power quality monitoring. These additional features are more than simple automated meter reading (AMR). They are similar in many respects to Advanced Metering Infrastructure (AMI) meters. Interval and time-of-use meters historically have been installed to measure commercial and industrial customers, but may not have automatic reading.

The UK consumer group, showed that as many as one in three confuse smart meters with energy monitors, also known as in-home display monitors. The roll-out of smart meters is one strategy for energy savings. While energy suppliers in the UK could save around £300 million a year from their introduction, consumer benefits will depend on people actively changing their energy use. For example, time of use tariffs offering lower rates at off-peak times, and selling electricity back to the grid with net metering, may also benefit to consumers.

The installed base of smart meters in Europe at the end of 2008 was about 39 million units, according to analyst firm Berg Insight [9]. Globally, Pike Research found that smart meter shipments were 17.4 million units for the first quarter of 2011. Vision gain determined that the value of the global smart meter market would reach \$7 billion in 2012. Smart meters may be part of a smart grid, but alone, they do not constitute a smart grid.

2. Energy meter or watt-hour meter

An instrument that is used to measure either quantity of electricity or energy, over a period of time is known as energy meter or watt-hour meter. In other words, energy is the total power delivered or consumed over an interval of time t may be expressed as:

$$W = \int_0^t v(t) i(t) dt$$

If,

$v(t)$ is expressed in volts,

$i(t)$ in amperes and

t in seconds, the unit of energy is joule or watt second.

The commercial unit of electrical energy is kilowatt hour (KWh). For measurement of energy in A.C. circuit, the meter used is based on “electromagnetic induction” principle. They are known as induction type instruments. The measurement of energy is based on the induction principle is particularly suitable for industrial or domestic meters on the account of lightness and robustness of the rotating element. Moreover, because of smallness of the variations of voltage and frequency in supply voltage, the accuracy of the induction meter is unaffected by such variations. If the waveform of the supply is badly distorted, the accuracy, however, is affected. Basically, the induction energy meter may be derived from the induction watt-meter by substituting for the spring control and pointer an

eddy current brake and a counting train, respectively. For the meter to read correctly, the speed of the moving system must be proportional to the power in the circuit in which the meter is connected.

2.1 Construction of induction type energy meter

Induction type energy meter essentially consists of following components

- a) Driving system
 - b) Moving system
 - c) Braking system
 - d) Registering system
- a) **Driving system**

The construction of the electro magnet system is shown in Figure 1 and it consists of two electromagnets, called “shunt” magnet and “series” magnet, of laminated construction.

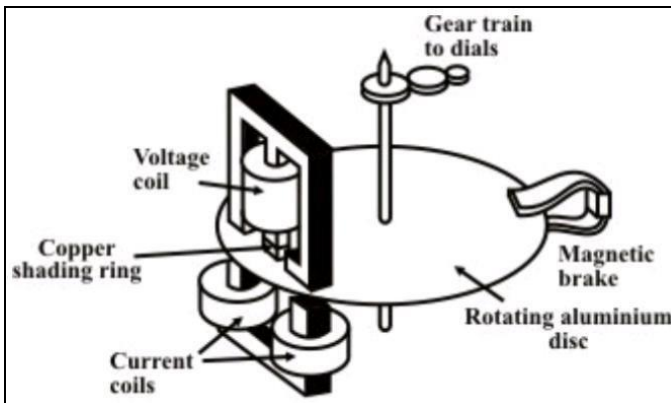

Fig 1: Watt hour meter

A coil having large number of turns of fine wire is wound on the middle limb of the shunt magnet. This coil is known as “pressure or voltage” coil and is connected across the supply mains. This voltage coil has many turns and is arranged to be as highly inductive as possible. In other words, the voltage coil produces a high ratio of inductance to resistance.

This causes the current, and therefore the flux, to lag the supply voltage by nearly 90°. Adjustable copper shading rings are provided on the central limb of the shunt magnet to make the phase angle displacement between magnetic field set up by shunt magnet and supply voltage is approximately

90. The copper shading bands are also called the power factor compensator or compensating loop. The series electromagnet is energized by a coil, known as “current” coil which is connected in series with the load so that it carry the load current. The flux produced by this magnet is proportional to, and in phase with the load current.

b) Moving system

The moving system essentially consists of a light rotating aluminum disk mounted on a vertical spindle or shaft. The shaft that supports the aluminium disk is connected by a gear arrangement to the clock mechanism on the front of the meter to provide information that consumed energy by the load. The time varying (sinusoidal) fluxes produced by shunt and series magnet induce eddy currents in the aluminium disc. The interaction between these two magnetic fields and eddy currents set up a driving torque in the disc. The number of rotations of the disk is therefore proportional to the energy consumed by the load in a certain time interval and is commonly measured in kilo watt-hours (Kwh).

c) Braking system

Damping of the disk is provided by a small permanent magnet, located diametrically opposite to the A.C magnets. The disk passes between the magnet gaps. The movement of rotating disc through the magnetic field crossing the air gap sets up eddy currents in the disc that reacts with the magnetic field and exerts a braking torque. By changing the position of the brake magnet or diverting some of the flux there from, the speed of the rotating disc can be controlled.

d) Registering or counting system

The registering or counting system essentially consists of gear train, driven either by worm or pinion gear on the disc shaft, which turns pointers that indicate on dials the number of times the disc has turned. The energy meter thus determines and adds together or integrates all the instantaneous power values so that total energy used over a period is thus known. Therefore, this type of meter is also called an “integrating” meter.

3. Operation of energy meter

Induction instruments operate in alternating-current circuits and they are useful only when the frequency and the supply voltage are approximately constant. The most commonly used technique is the shaded pole induction watt-hour meter.

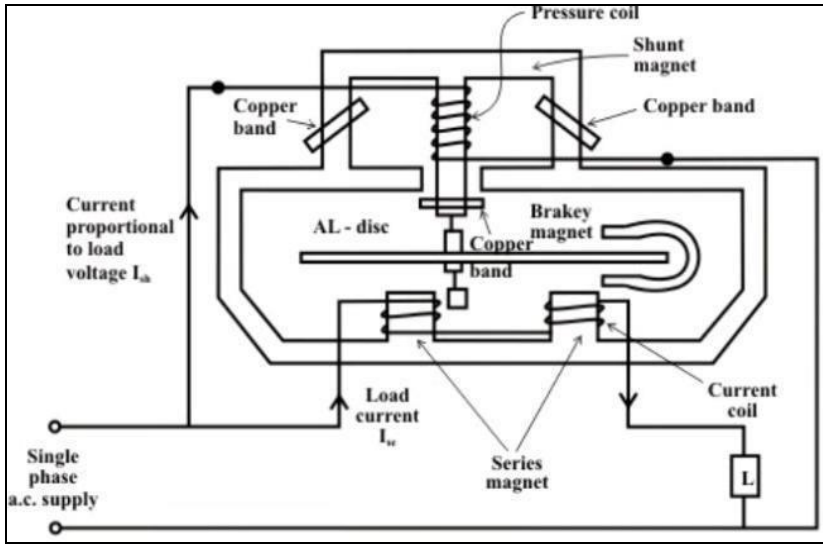

Fig 2: Basic operation

The rotating element is an aluminium disc, and the torque is produced by the interaction of eddy currents generated in the disc with the imposed magnetic fields that are produced by the voltage and current coils of the energy meter. Let us consider a sinusoidal flux $\phi(t)$ is acting perpendicularly to the plane of the aluminium disc, the direction of eddy current by Lenz's law is indicated in Figure 2. It is now quite important to investigate whether any torque will develop in aluminium disc by interaction of a sinusoidally varying flux $\phi(t)$ and the eddy currents induced by itself.

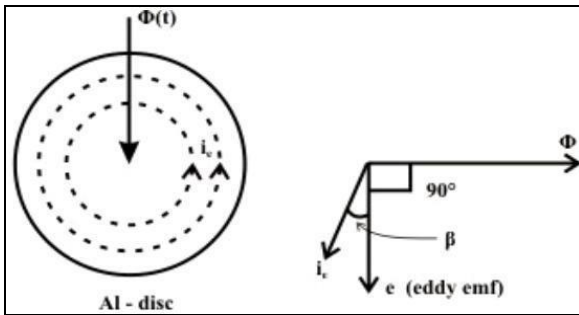

Fig 3: Eddy current in aluminium disc due to time varying flux

$$T_{d(av.)} \propto \phi I_e \cos(\angle \phi, I_e) = \phi I_e \cos(90^\circ + \beta)$$

$$\propto \phi I_e \sin(\beta) \approx 0$$

Where ϕ and I.e. are expressed in R.M.S and $\beta=0$ (because the reactance of the aluminium disc is nearly equal to zero). Therefore, the interaction of a sinusoidally varying flux $\phi(t)$ and its own eddy current i.e. (induced) cannot produce torque any on the disc.

So in all induction instruments we have two fluxes produce by currents flowing in the windings of the instrument. These fluxes are alternating in nature and so they induce emfs in a aluminium disc or a drum provided for the purpose. These emfs in turn circulate eddy currents in the disc. As in an energy meter instrument, we have two fluxes and two eddy currents and therefore two torques are produced by

- i) First flux(ϕ_1) interacting with the eddy currents (I_e2) generated by the second flux(ϕ_2).
- ii) Second flux (ϕ_2) interacting with the eddy currents (I_e2) induced by the first flux(ϕ_1).

3.1 Errors in the energy meter

Assuming the supply voltage and frequency constant, the induction type energy may have the following errors:

3.1.1 Speed error

Due to the incorrect position of the brake magnet, the braking torque is not correctly developed. This can be tested when meter runs at its full load current alternatively on loads of unity power factor and a low lagging power factor. The speed can be adjusted to the correct value by varying the position of the braking magnet towards the Centre of the disc or away from the Centre and the shielding loop. If the meter runs fast on inductive load and correctly on non-inductive load, the shielding loop must be moved towards the disc. On the other hand, if the meter runs slow on non- inductive load, the brake magnet must be moved towards the center of the disc.

3.1.2 Meter phase error

An error due to in correct adjustment of the position of shading band results an incorrect phase displacement between the magnetic flux and the supply voltage (not in quadrature). This is tested with 0.5 P.F. load at the rated load condition. By adjusting the position of the copper shading band in the central limb of the shunt magnet this error can be eliminated.

3.1.3 Friction error

An additional amount of driving torque is required to compensate this error. The two shading bands on the limbs are adjusted to create this extra

torque. This adjustment is done at low load (at about ¼th of full load at unity P.F.).

3.1.4 Creep

In some meters a slow but continuous rotation is seen when pressure coil is excited but with no load current flowing. This slow revolution records some energy. This is called the creep error. This slow motion may be due to

1. Incorrect friction compensation.
2. To stray magnetic field.
3. For over voltage across the voltage coil.

This can be eliminated by drilling two holes or slots in the disc on opposite side of the spindle. When one of the holes comes under the poles of shunt magnet, the rotation being thus limited to a maximum of. In some cases, a small piece of iron tongue or vane is fitted to the edge of the disc. When the position of the vane is adjacent to the brake magnet, the attractive force between the iron tongue or vane and brake magnet is just sufficient to stop slow motion of the disc with full shunt excitation and under no load condition.

3.1.5 Temperature effect

Energy meters are almost inherently free from errors due to temperature variations. Temperature affects both driving and braking torques equally (with the increase in temperature the resistance of the induced-current path in the disc is also increases) and so produces negligible error. A flux level in the brake magnet decreases with increase in temperature and introduces a small error in the meter readings. This error is frequently taken as negligible, but in modern energy meters compensation is adopted in the form of flux divider on the break magnet.

Energy meter constant K is defined as $K = \text{No. of revolutions/kwh}$

In commercial meters the speed of the disc is of the order of 1800 revolutions per hour at full load.

3.2 Theft resistant energy meters

By Paul Daigle, Product Manager at Analog Devices Inc, Wilmington, Massachusetts only profitable businesses can offer high quality at an occasional discount. Utility companies are no different. All honest consumers of electricity would like everyone else that uses electricity to also pay for their fair share of electricity so that quality of distribution can improve. With the advent of electronic energy meters, utility companies have

a wide selection of approaches to combat theft on their grid. The breadth of selection depends up on the available infrastructure and investment capital available.

The most robust and technically superior solution would approach the elusive goal of a tamper-proof meter. This elegant solution would monitor every energy meter remotely and capture an energy consumption reading every 15 or 30 minutes. Usage patterns could be monitored and abnormalities detected. A decision could be made to discontinue service remotely. Potential lost revenue from consumer misuse is eliminated quickly and the likelihood of corruption is curtailed significantly.

The success of an automatic meter reading solution relies on utility companies willing to take the risk of investing in a communications network and a data management infrastructure. The return on investment of such an installation project complicated by political agendas is difficult to justify before a real-life testimonial can be used as an example. Based on risk and economic environment, utility companies in developing countries are forced to adopt a low-cost approach instead of a technically superior solution.

Most of the electricity in developing countries is distributed on two wire, single phase. The functional equivalent to the electromechanical meter is an electronic energy meter that measures current in the phase wire. An example of the typical connection on a standard electronic energy meter used for two wire, single phase distribution is shown in figure 1. This configuration, installed by utility companies, allows correct billing by monitoring current only in the phase wire but this is not sufficient to bill correctly under popular tampering schemes. This example uses a current transformer as the transducer on the phase current path.

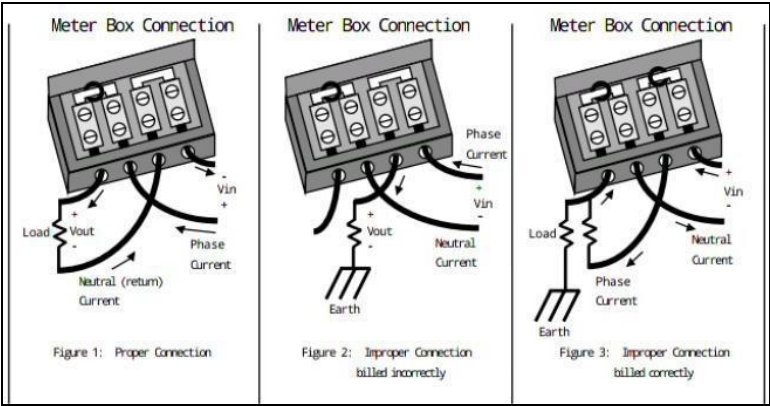

Fig 3: Theft resistance energy meter

A popular approach to designing a tamper resistant energy meter monitors current in both the phase and return path. Monitoring both phase and neutral and calculating real average power based on the larger of the two currents eliminates most pilfering schemes that tamper with the current path through the energy meter. A mechanical meter or an electronic meter with a single current transducer is unable to detect power consumption of the load in the configuration shown in Figure 3. Figure 3 illustrates blatant tampering that is easy to detect with visual inspection. Figure 3 illustrates a more subtle approach. All connections to the meter are correct but not all of the current supplied to the load is returned through the meter. A popular tactic that is difficult to detect is to reduce the size of one's bill by creating a partial earth fault. This illustration uses two current transformers that are fairly well matched to eliminate the need for calibration of the second current channel. The meter bills according to the larger of the phase or neutral currents.

These types of simple tampering schemes can cost power generation and distribution companies lots of money when implemented on high current loads. The cost for implementing a meter capable of reliably detecting differences in phase and neutral currents at very low currents is probably unwarranted. Electronic energy meter manufacturers have been designing these systems with multiple integrated circuits. The multiplexers and comparators used in these schemes increase component count and are not able to bill accurately under a fault condition. The AD7751 integrates this functionality onto a single chip to eliminate switching and threshold noise while reducing component count. A fault is indicated when the phase and neutral currents differ by more than 12.5%. Billing is continued using the larger of the two currents. The lowest cost meter still requires manual reading of mechanical counter. The AD7751 drives the stepper motor counter directly to facilitate the lowest cost design.

4. Automatic SAMRT energy meter reading

In the most of the developing country like Sri Lanka a personnel from utility company goes at every house to take the readings of meters for billing purpose. It is a time-consuming task which requires a great number of labours. This system of automated wireless meter reading is based on the same principle of wireless data transmission that is used in power theft detection and controlling system. In the proposed method GSM technology used to transmit the meter reading data from customer meter site to the utility company. The automated wireless meter reading system (AMR) shown in the Fig. 1 installed in the consumer site meter counts the meter reading data using the microcontroller and sends to the utility company with

some identification parameter once in a month or on request of the operator. The internal structure of the AMR is described in Figure. 4

Utility company consists of GSM based wireless data receiver device with microcontroller and display. When the device is in the range of data response it receives the data transmitted by the consumer side meter. Each consumer is identified using subscriber identification module (SIM) identification number installed in the AMR.

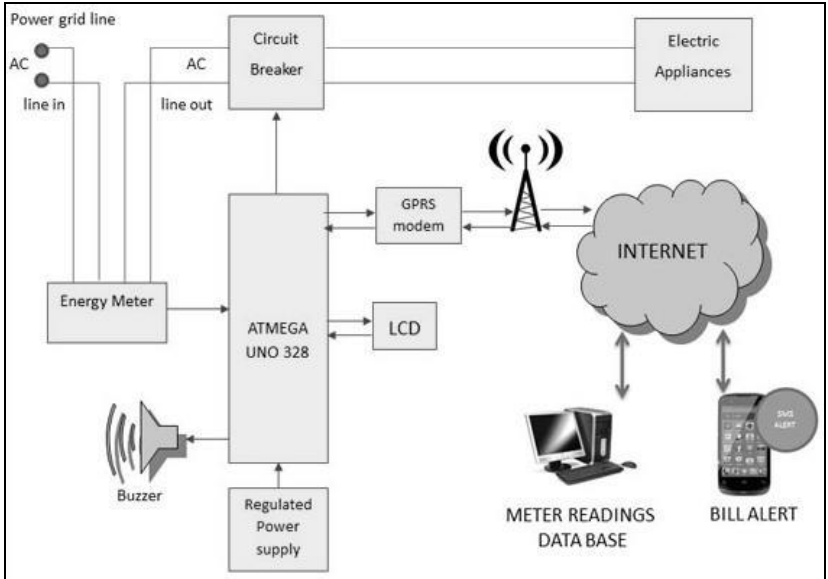

Fig 4: Smart AMR system

5. Conclusion

The home energy monitoring system has been developed to measure power consumption which helps to reduce the energy use in domestic areas through visible energy displays. Communication between Lab VIEW and consuming power module helped us to monitor the power consumption for plotting recent and historical data to optimize control and planning of energy consumption.

5.1 Future scope

- It will be used in prepaid and postpaid energy meter.
- By using this we avoid voltage fluctuations and power theft.
- We regulate the maximum power consumption loads then automatically life span of natural source will increase.

6. References

1. Tan HGR, Lee CH, Mok VH. Automatic power meter reading system using GSM network, International Power Engineering Conference (IPEC), Singapore, 2007, 465-469.
2. Rana Zahid Iqbal, Waseem, Muhammad, Mahmood Tahir. Automatic Energy Meter Reading using Smart Energy Meter, 2014. 10.13140/RG.2.1.1343.7928.
3. Electrical and Electronics Measurements and Instrumentation Engineering by Nilkanta Data.
4. Malhotra P, Seethalakshmi R. Automatic Meter Reading and Theft Control System by using GSM. International Journal of Engineering and Technology. A Course in Electronic Measurements and Instrumentation by A K Sawhney, 2013; 5:806-810.
5. Rana, Zahid Iqbal, Waseem, Muhammad, Mahmood, Tahir. Automatic Energy Meter Reading using Smart Energy Meter, 2014. 10.13140/RG.2.1.1343.7928.
6. Agustín Zaballos, Alex Vallejo, Marta Majoral, Josep M Selga. Survey and Performance Comparison of AMR Over PLC Standards, IEEE transactions on power delivery, 2009, 24(2).
7. Smart energy meter available at [http:// en.wikipedia.org/wiki/smart energy meter](http://en.wikipedia.org/wiki/smart_energy_meter).

Chapter - 6
A Novel Approach of Image De-Noising using
Implementation of the DWT and HWT
Techniques

Authors

B. Malakonda Reddy

Department of Electronics and Communication Engineering,
Narayana Engineering College, Gudur, Andhra Pradesh, India

Raja Reddy Duvvuru

Department of Electrical & Electronics Engineering, Malla
Reddy Engineering College (Autonomous), Hyderabad,
Telangana, India

Dr. P. Hemachandu

Professor, EEE Sasi Institute of Technology & Engineering
(Autonomous), Tadepalligudem, Andhra Pradesh, India

Dr. A. Pulla Reddy

Associate Professor, ECE, Chadalawada Ramanamma
Engineering College, Tirupati, Andhra Pradesh, India

Chapter - 6

A Novel Approach of Image De-Noising using Implementation of the DWT and HWT Techniques

B. Malakonda Reddy, Raja Reddy Duvvuru, Dr. P. Hemachandu and Dr. A. Pulla Reddy

Abstract

Wavelets are due to their multilevel deterioration capacity, territory common decision for pressure. Representing a sign at various goals permits to catch its primary patterns in just a couple of coefficients while confining discontinuities unequivocally. A predetermined channel set is utilized for examination if there should arise an occurrence of dual-tree complex wavelet transform (DTCWT). This constraint can be defeated in ADWT, as any mother wavelet can be utilized for investigation. Another two-dimensional WT called Hyperanalytic wavelet transform (HWT) is thought of. It is the speculation in 2D space of ADWT. HWT can be improved by finding a superior usage of Hilbert Transform, in this way diminishing estimated blunders. It has semi move invariance, great directional selectivity having the option to isolate diverse orientated points. The benefit of utilizing HWT is any wavelet family can be utilized to improve the directionality over 2-D Dual Tree Complex Wavelet Transform. The calculation is actualized on standard pictures alongside wiener channel and contrasted and spatial wiener technique and DWT based wiener sifting.

Keywords: DTCWT, HWT, image processing

I. Introduction

Since their presentation two decades prior, wavelets have increased impressive enthusiasm for signal preparing. The proposed work genuinely targets expelling the restrictions of the existing picture pressure calculations^[1-3] which have been altogether considered. Initially, a calculation is proposed utilizing DCT alongside versatile down testing which contrasts well and JPEG execution. The exhibition of this calculation has been bettered by utilizing adjusted down testing alongside DWT for pressure. Appropriate wavelets have been developed for this reason. Additionally, this proposed calculation naturally picks between different down testing modes

and different insertion modes for ideal portrayal and higher pressure. This calculation is additionally picture free and works productively on low-detail, medium-detail just as high-detail pictures, giving great pressure proportions while keeping up the visual centrality of the images. The restrictions of the DWT can be overwhelmed by utilizing the HWT whose development expels the constraints innate in DWT. Until now, HWT has been broadly proposed for picture de-noising ^[4-6], yet has never been utilized for picture pressure. The unrivaled directional selectivity of HWT has been utilized in this work. By and by, a calculation is proposed for utilizing HWT for picture pressure alongside SPIHT encoding.

II. Image implementation using DWT and HWT

In fig.1, one level and two level 2D DWT for a dim and hued Lena picture are appeared. As extra data about picture is gotten by expanding the degree of wavelet deterioration, further examination can be completed. In any case, it endures a few impediments, for example, move affectability, directional selectivity, nonattendance of stage data. These can be overwhelmed by presenting one of the accompanying investigative wavelet change called Hyperanalytic Wavelet Transform. The definite usage of HWT is clarified in area 3.6. The Hyperanalytic Wavelet Transform usage of picture Lena is appeared in the fig.2. HWT gives extra directional data in the picture contrasted with the data acquired utilizing Discrete Wavelet Transform. In the fig. 3 the DWT and HWT computation are observed. From the fig. 3 clearly, a few headings are missing in the DWT, all the rich bearings in the picture are introduced in the HWT of the picture. In the above outcomes, the HWT results introduced for shading pictures just, yet it is even appropriate to dark pictures moreover ^[7]. The directional coefficients of HWT, for example, Z_{R+} , Z_{R-} , Z_{I+} and Z_{I-} are appeared in the fig. 4.

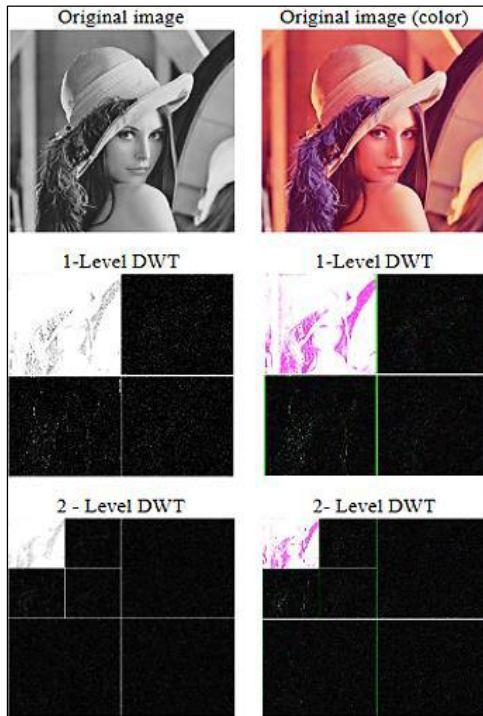

Fig 1: 2-D view of DWT illustrations of gray and colour images



Fig 2: HWT image of Lena image

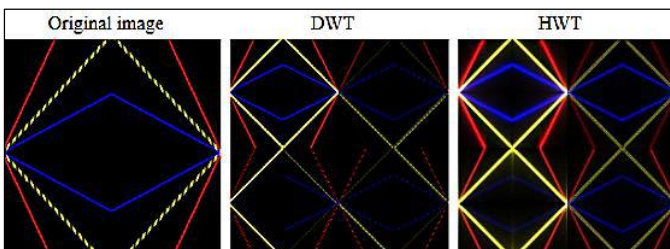

Fig 3: Image of DWT and HWT

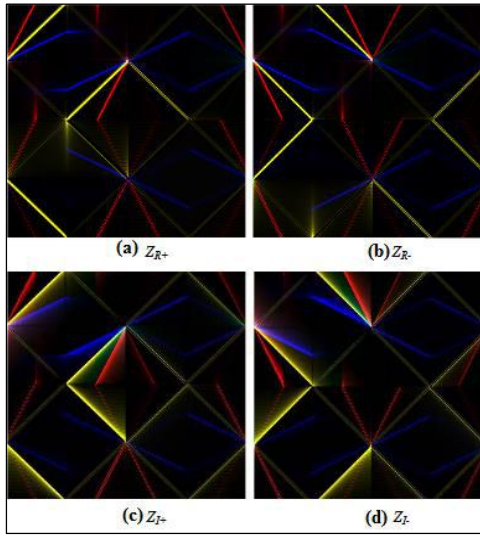

Fig 4: Images of directional coefficients of HWT

III. Image denoising using HWT and DWT

The denoising techniques dependent on the utilization of a zero-request wiener channel in the wavelet space can't totally expel the commotion when the sign to the clamor proportion of the obtained picture is low. The after effect of denoising utilizing DWT can be somewhat improved on the off chance that we supplant the 2D DWT by the HWT [8-9]. The speculation utilized for the development of the neighbour-hood minor zero request Wiener channel in the 2D DWT area can be applied on account of the four segments of the detail HWT coefficients.

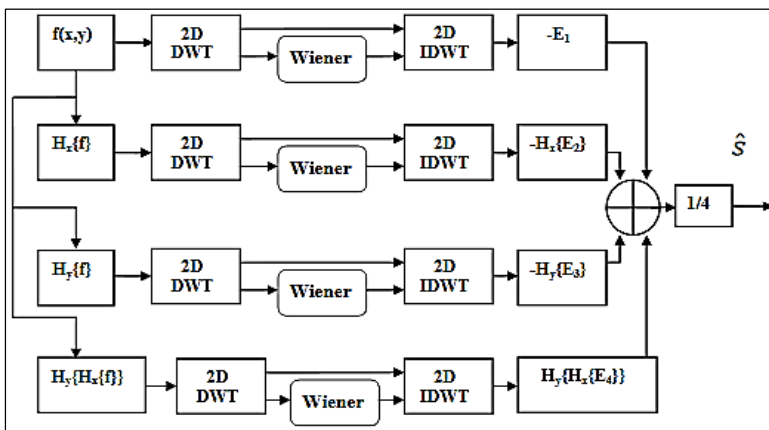

Fig 5: Denoising method using HWT and Zero-Order Wiener filter

Like the denoising utilizing wavelet change introduced in the past segment, the denoising utilizing HWT, additionally, conveyed by processing the four DWTs of the picture, one on the genuine picture, one on the system got by playing out the Hilbert Transform along lines of picture H_X , another on the grid acquired by performing Hilbert Transform along segments of the picture H_Y , and keep going on the lattice got by performing Hilbert Transform along segments of the network got by performing Hilbert Transform along the columns of the picture $H_Y(H_X)$. The detail coefficients of every wavelet change are separated with a zero request Wiener channel. With the resultant detail coefficients and unfiltered estimation coefficients, the opposite wavelet change is registered ^[10].

The inverse activity is performed on the consequences of opposite wavelet changes of the coefficients, for example $-H_X$ of the subsequent tree, $-H_Y$ of the third tree and $-H_Y (-H_X)$ of fourth tree are registered and the normal of all the four trees gives the denoised picture ^[11]. The denoising calculation utilizing HWT is appeared in the fig. 5. In processing HWT and opposite HWT, the Hilbert changes assume an essential job. The Hilbert changes is figured utilizing the Hilbert capacity and converse Hilbert change is processed as negative of Hilbert change of changed sign, in the MATLAB. While deciding the converse Hilbert change in the MATLAB, it isn't completely held to the first sign or picture, some mistake happens. This blunder is limited, if the length of the sign or size of the picture is expanded, and the mistake is boosted, if the size of the picture is diminished. The agent presents the wiener sifting based denoising calculations as follows ^[12-14]. The proposed calculation is tried for the pictures of size of 512×512 , 768×768 and 1024×1024 .

1. Spatial wiener channel
2. Discrete Wavelet Transform (DWT) with wiener separating the nitty gritty coefficients
3. HWT with wiener separating the nitty gritty coefficients ^[15]

IV. Results and Discussion

The results conversation is introduced for HWT based picture denoising alongside wiener channel and contrasted and spatial wiener channel technique and DWT based wiener strategy as follows: For the picture 'Lena', the Gaussian clamor is included with $\sigma = 10, 20, 30, 40$ and 50 . For this loud picture, the various calculations viz., denoising utilizing Spatial Wiener Filter, Denoising utilizing DWT and Denoising utilizing HWT are examined. The presentation of every technique is assessed by deciding the Peak Signal

Noise Ratio (PSNR) and mean square for various estimations of σ . Every one of these outcomes are organized as demonstrated as follows. For the creative image in fig.6a, the gaussian noise with $\sigma = 10$ is additional and the corrupted image in fig.6b is denoised with spatial wiener filter in fig.6c, denoised with DWT in fig.6d and denoised with HWT in fig.6.

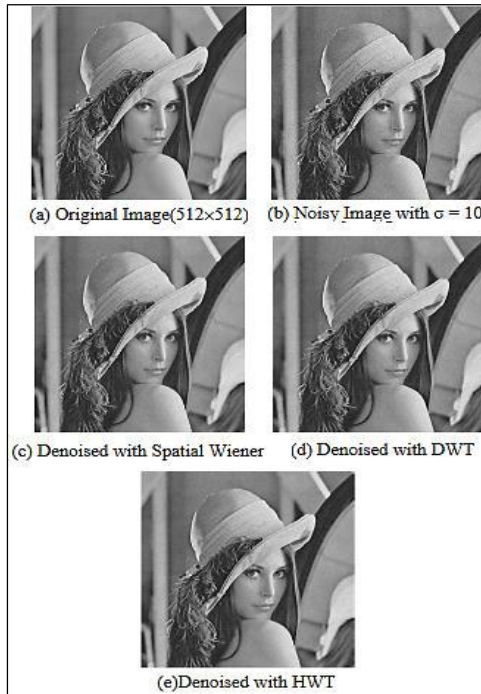

Fig 6: One example of denoising using wiener filters of 'Lena' image (512x512)

The PSNR for the denoised picture 'Peppers' is more prominent than that of picture 'Lena' in all the strategies viz., denoising utilizing spatial wiener channel, denoising utilizing DWT and denoising utilizing HWT. The MSE is conversely identified with PSNR, that is, MSE for the denoised picture 'Peppers' is littler than that of picture 'Lena' in every one of the three denoising techniques introduced. For 'Lena' picture, the PSNR of the DWT strategy is littler than that of spatial Wiener channel for the σ under 25, after which DWT technique gives preferred PSNR over that in spatial Wiener Filter. Additionally, the equivalent can be clarified with MSE.

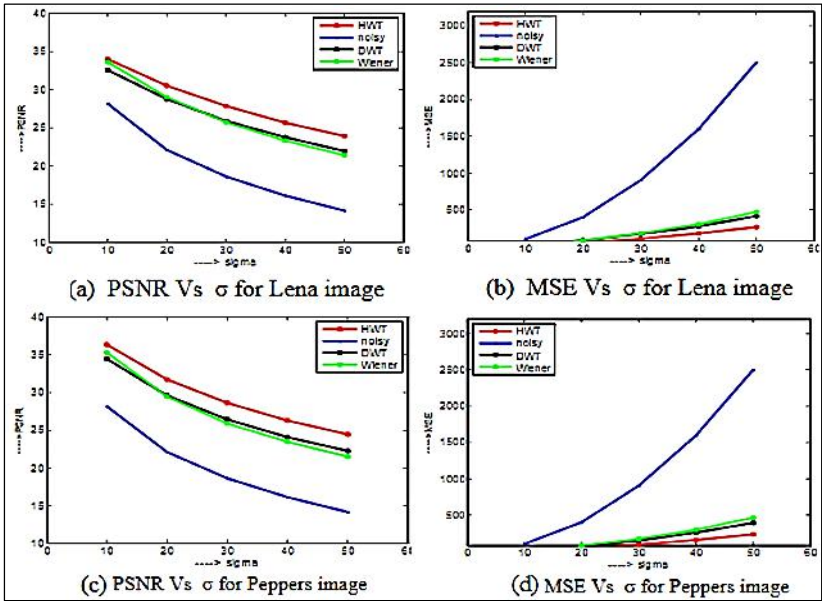

Fig 6: Comparison of PSNR & σ for Peppers image

V. Conclusion

In this work wiener filtering based denoising algorithms in spatial domain and transform domain filtering (DWT and HWT) is explained. The results are compared and analyzed for different images with different spatial resolutions. From the investigation results it is obvious that denoising with HWT performs better than denoising with DWT and spatial methods. It is also observed that there is PSNR improvement with increase in spatial resolution.

References

1. Gonzalez R, Woods R. Digital Image Processing, Addison-Wesley, 3 edition, Wilmington, USA.
2. Jain A. Fundamentals of Digital Image Processing, Prentice-Hall, Cambridge, 1996.
3. Glassner A. Principles of Digital Image Synthesis, Morgan Kaufman, San Francisco.
4. Gaoyong Luo. Fast Wavelet Image Denoising Based on Local Variance and Edge Analysis, International Journal of Computer Systems Science and Engineering, 1(2):165-175.

5. Arivazhagan S, Deivalakshmi S, Kannan K. Performance Analysis of Image Denoising System for different levels of Wavelet decomposition, *International Journal of Imaging Science and Engineering*. 2007; 1(3):104-107.
6. McVeigh ER, Henkelman RM, Bronskill MJ. Noise and filtration in magnetic resonance imaging, *Med. Phys.* 1985; 12(5):586-591.
7. Kai-qi Huang, Zhen-yang Wu, George SK Fung, Francis HY Chan. Color image denoising with wavelet thresholding based on human visual system model, *Signal Processing: Image Communication*. 2005; 20(2):115-127.
8. Yang Sua, Zhijie Xu. Parallel implementation of wavelet-based image denoising on programmable PC-grade graphics hardware, *Signal Processing*, 2009.
9. Foucher S, Benie GB *et al.*, Multi scale MAP Filtering of SAR images, *IEEE Transactions on Image Processing*. 2001; 10(1):49-60.
10. Alexandru ISAR, Andrei Cubitchi, Miranda Nafornita. *Algorithmes et techniques de compression*, Editura Orizonturi Universitare, Timisoara, 2002.
11. I. JTC1/SC29/WG1. JPEG lossless and lossy compression of continuous- tone and bi-level still images Part 1: Minimum decoder. Final committee draft, Version 1.0., 2000.
12. Wallace G. The JPEG still picture compression standard, *IEEE TCE*, 38, 1992.
13. Grossman A, Morlet J. Decomposition of Hardy functions into square integrable wavelets of constant shape, *SIAM J Math. Anal.* 1984; 15:723-736.
14. Ivan W Selesnick, Richard G Baraniuk, Nick G Kingsbury. The Dual-Tree Complex Wavelet Transform, *IEEE Signal Processing Magazine*. 2005; 22(6):123-151.
15. Ding Hong-Bo, Pan Zhong-Xiao, Yu Xing-Zeng, Zheng Fu-Yang, Renato Seeber. The Preliminary Study for the Interpretation of Electrochemical Noise with Continuous Wavelet Transform, *The journal of corrosion science and engineering*, 1999, 1(10).